

# User's Manual

## Household Air to Water Heat Pump

---

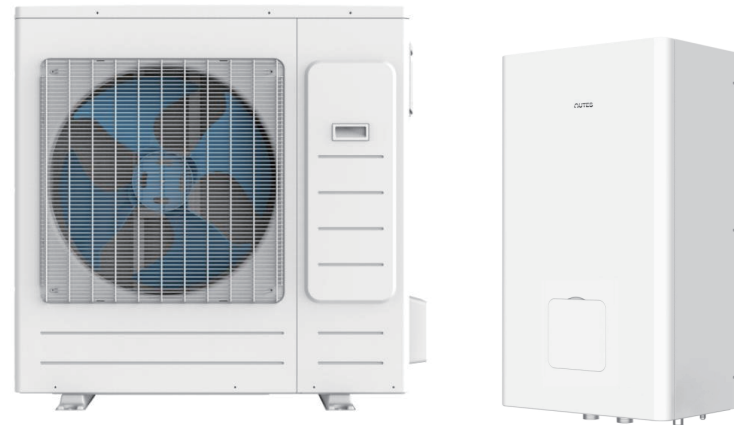

## Catalog

1. Instructions .....	1
1.1 Safety Warning .....	1
1.2 Preparation before the Installation .....	3
1.3 Preparation before the Test Run .....	4
1.4 Important Information .....	4
2. System Description .....	5
2.1 Heat Pump Structure Diagram .....	5
2.2 Three-dimensional Structure of Heat Pump .....	6
2.3 Heat Pump System .....	7
2.4 Heat Pump & Boiler System .....	10
2.5 Solar Energy System .....	16
3. Installation .....	19
3.1 Instructions .....	19
3.2 Safety Rules .....	21
3.3 Transport and Storage .....	21
3.4 Installation Cautions .....	22
3.5 Installation Space .....	26
3.6 Water Pipe Connection .....	31
3.7 Electrical Installation .....	37
3.8 Electrical Wiring Diagram .....	38
3.9 Wiring Diagram .....	39
3.10 Indoor Unit Code Dialing .....	41
4. Wired Controller Operation Instruction .....	42
4.1 Initial Interface .....	42
4.2 User interface .....	45
5. Backup Heat Source Instruction .....	53
5.1 Backup Heat Source (Boiler) Management .....	53
5.2 Solar Management (Optional) .....	53
5.3 Auxiliary Electric Heater (Optional) .....	53
6. Commissioning .....	54
7. Specifications .....	55
7.1 Nomenclature .....	55
7.2 Technical Parameters .....	55
8. Maintenance and Fault .....	60
9. Installation Record .....	68

## Instructions

	Correct Disposal of this product
	This marking indicates that this product should not be disposed with other household wastes throughout the EU. To prevent possible harm to the environment or human health from uncontrolled waste disposal, recycle it responsibly to promote the sustainable reuse of material resources. To return your used device, please use the return and collection systems or contact the retailer where the product was purchased. They can take this product for environmental safe recycling.

### 1.1 Safety warning

#### Warning!

The machine uses R32 flammable refrigerant.

This machine shall be installed in a well-ventilated room without continuous fire source, and the room area during installation shall not be less than the datum in the following table:

Machine capacity	4-6KW	8KW	10KW	12-16KW
Mini. room area	no request	2m <sup>2</sup>	2m <sup>2</sup>	3.5m <sup>2</sup>

Before maintenance or repair the machine which use R32 refrigerant, safety inspection must be carried out to ensure that the risk of danger is minimized.



#### Warning!

The DC inverter heat pump air-cooled cold (hot) water unit (hereinafter referred to as the unit or heat pump) during installation must comply with all national and local regulations. Please read the instructions carefully before installing the unit. Follow the installation and maintenance manual in order to ensure reliable operation. The unit installation must be completed by the company designated professionals.

## Warning!

- In order to avoid damage to persons and property , please turn off the power before installing this system. Before installing and using this product, please read this manual carefully.
- The appliance shall be installed in accordance with national wiring regulations.
- This manual can't cover all situations encountered in unit installation, it is impossible for all the possibilities that appear during installation. If you need more detailed information or face special problems raised by the customer which are not described in detail in this manual, please contact us.
- The foundation must be solid and reliable to withstand the unit's weight, if the installed base of the unit can't bear its weight, the unit may collapse causing unnecessary damage to property or personal injury when the unit is running.
- Installation and operation of space should ensure good ventilation, otherwise refrigerant leakage happened and met the fire, toxic gases will produce.
- Do not use means to accelerate the defrosting process or to clean, other than those recommended by the manufacturer.
- The appliance shall be stored in a room without continuously operating ignition sources (for example: open flames, an operating gas appliance or an operating electric heater.)
- Do not pierce or burn.
- Be aware that refrigerants may not contain an odour.
- Compliance with national gas regulations shall be observed.
- A notice that servicing shall be performed only as recommended by the manufacturer.
- A warning that the appliance shall be stored in a well-ventilated area where the room size corresponds to the room area as specified for operation.
- The appliance shall be stored so as to prevent mechanical damage from occurring.
- Any person who is involved with working on or breaking into a refrigerant circuit should hold a current valid certificate from an industry-accredited assessment authority, which authorises their competence to handle refrigerants safely in accordance with an industry recognised assessment specification.
- Servicing shall only be performed as recommended by the equipment manufacturer. Maintenance and repair requiring the assistance of other skilled personnel shall be carried out under the supervision of the person competent in the use of flammable refrigerants.
- Make sure the unit uses the specified refrigerant (check its technical specifications) before installation and moving. The refrigerant can't be mixed with other refrigerants. And the air can't remain in the refrigerant line, because the air is incompressible gas, it causes the too high system pressure resulting in pipeline rupture or other damage.
- Authorized parts by must be used. The user can ask authorized dealer or technician for it.
- Improper installation of accessories may cause electric shock, water leakage or fire.
- If the supply cord is damaged, it must be replaced by the manufacturer, its service agent or similarly qualified persons in order to avoid a hazard.
- Do not operate your air conditioner in a wet room such as a bathroom or laundry room.
- Users can not repair or move units themselves. Otherwise it may cause an electric shock, leakage, fire.
- If the unit needs to be repaired or moved, the user must consult the dealer or technician and ask them to do it.
- After the installation, make sure there are no leaks of refrigerant. If the refrigerant leaks into the room to meet the fire, it will produce toxic gases. A large number of refrigerant leaks in a confined space can cause suffocation and other injuries.

- Use clean water that meets the quality standards. Sewage can cause system failure or leakage.
- This appliance can be used by children aged from 8 years and above and persons with reduced physical, sensory or mental capabilities or lack of experience and knowledge if they have been given supervision or instruction concerning use of the appliance in a safe way and understand the hazards involved. Children shall not play with the appliance. Cleaning and user maintenance shall not be made by children without supervision.( EN)
- This appliance is not intended for use by persons (including children) with reduced physical, sensory or mental capabilities, or lack of experience and knowledge, unless they have been given supervision or instruction concerning use of the appliance by a person responsible for their safety. ( IEC)
- Children should be supervised to ensure that they do not play with the appliance. ( IEC)

## 1.2 Preparation before the installation

### Warning!

- Do not install the unit in harsh environments . If the unit is installed in a steam and volatile oil, sulfur gases, exposed to salty air, snow-covered environment, the performance will weaken and it will damage the internal parts.
- Do not install the unit in a flammable gas. The flammable gases around the unit may cause burning or explosion.
- Make sure there are drain pipes for condensate and defrost water that produced by outdoor unit in heating mode.
- Caution must be taken when move the unit and wear protective gloves to prevent scratches.
- Ensure proper handling of packaging materials, including nails, other metals and wood materials which can cause damage.
- All electrical work must be performed by professional and technical personnel in accordance with local regulations and manuals.
- You must install the breaker . If not, there may be danger of electric shock.
- Must use standard cable as power line, while ensure that it can withstand enough current, or it may cause a short circuit, cable overheat causing a fire.
- Grounding line can't connect with gas pipeline or water pipelines or telephone grounding line. If the unit is not reliably grounded, it may be damaged by lightning. If the human body touches the unit, there will be the risk of electric shock when the unit leaks current.
- Make sure the circuit breaker is used (grounding line breakers, disconnecting switches, fuses, molded case circuit breaker) is prescribed capacity if the circuit breaker capacity does not conform the specified capacity , malfunction or fire will occur.
- Outdoor junction box must be fixed firmly lid tightly closed . If the cover panel is installed properly, dust or water will enter inside the box, it may result in electric shock or fire.
- An all-pole disconnection device which has at least 3mm clearances in all poles , and have a leakage current that may exceed 10mA, the residual current device (RCD) having a rated residual operating current not exceeding 30mA, and disconnection must be incorporated in the fixed wiring in accordance with the wiring rules.
- Outdoor junction box must be fixed firmly and cover must be tightly closed. If the cover panel is installed properly, dust or water will enter inside the box, it may result in electric shock or fire.

### 1.3 Preparation before the test run

#### Attention!

- Before starting, open the main power switch more than 12 hours. If you turn on the main power immediately after the start, it would seriously damage the internal components. During the operation the main power switch keeps on.
- Before starting operation, check all panels, alarms and other protective components whether they are installed correctly. Do not touch rotating, hot or high-pressure part.
- Do not touch any switches with wet hands, or there will be danger of electric shock.
- Do not touch the refrigerant piping with bare-hand during unit operation. Refrigerant piping is hot or cold depending on its mode of operation, there may be danger of burns or frostbite.
- Do not use unapproved refrigerants, refrigerant substitutes, or refrigerant additives.

### 1.4 Important information

#### Attention!

- Note: The user must carefully read the manual and can't set up or modify the unit procedures and parameters, which could cause serious unit failure.
- Those with physical disabilities or mental illness, and un-experienced people (including children) can't use the unit unless they have a guardian or someone to guide them to use and is responsible for their safety. To supervise children, make sure they do not touch the equipment.
- Unit must be installed by qualified persons in accordance with equipment installation and maintenance manual, while the unit can only have one person to open, before opening it to switch off all circuits. Cooling system must be undertaken by full-time staff.

#### Warning!

- In the winter, the heat pump is not required in a short-term, do not cut off the unit power supply, because the power is required for frost protection.
- If the unit power supply is failure or the unit is not used for a long time in winter, put the entire system of water drained to avoid damage due to freezing before heat pump system shut down.

## System Description

### 2.1 Heat pump structure diagram

#### Outdoor Unit

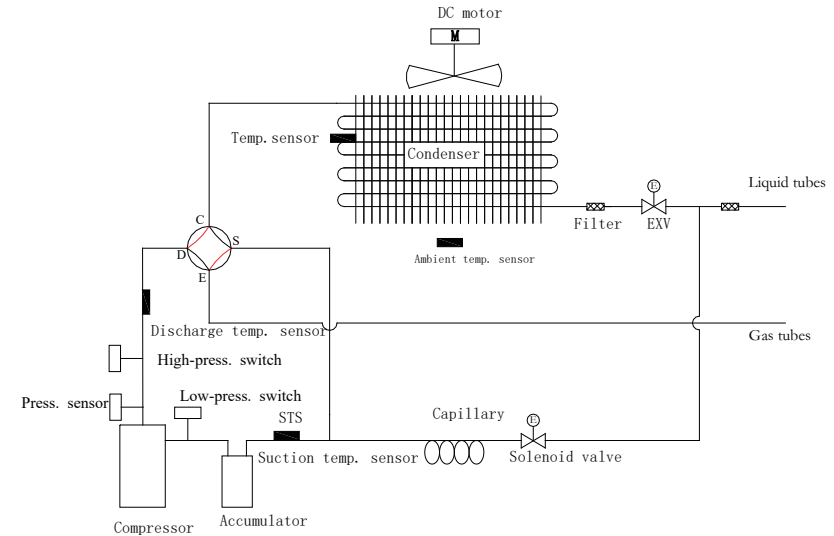

#### Indoor Unit

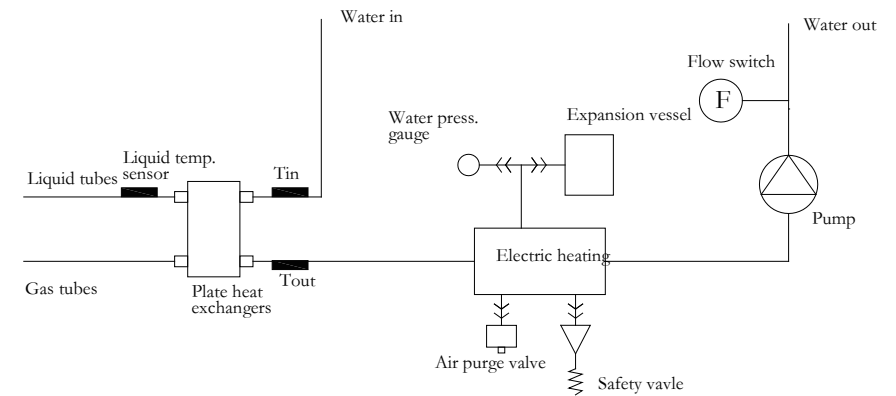



## 2.2 Three-dimensional structure of the heat pump

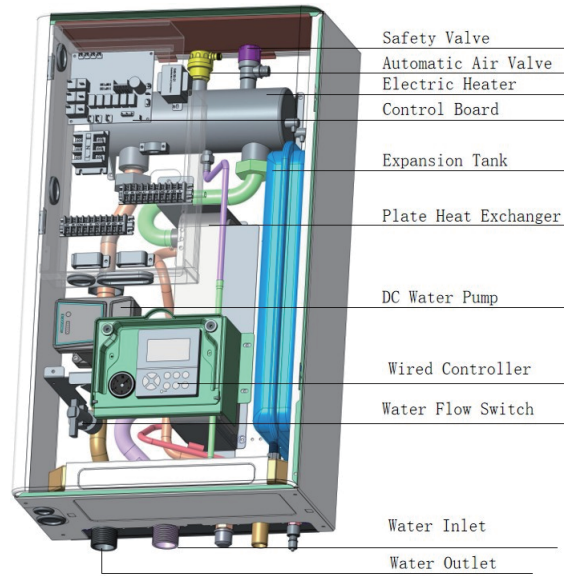

## 2.3 Heat pump system

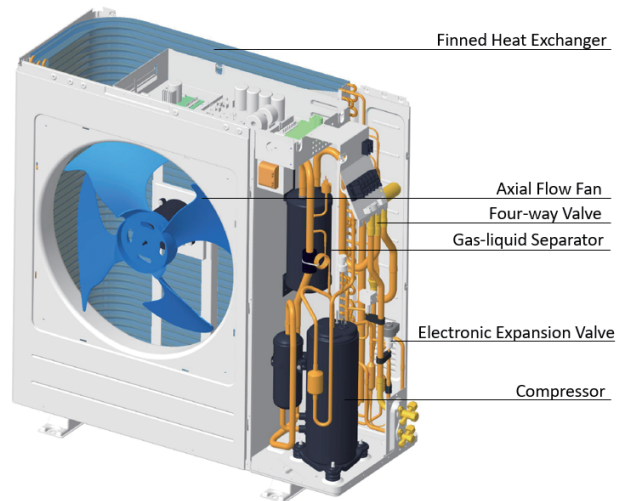
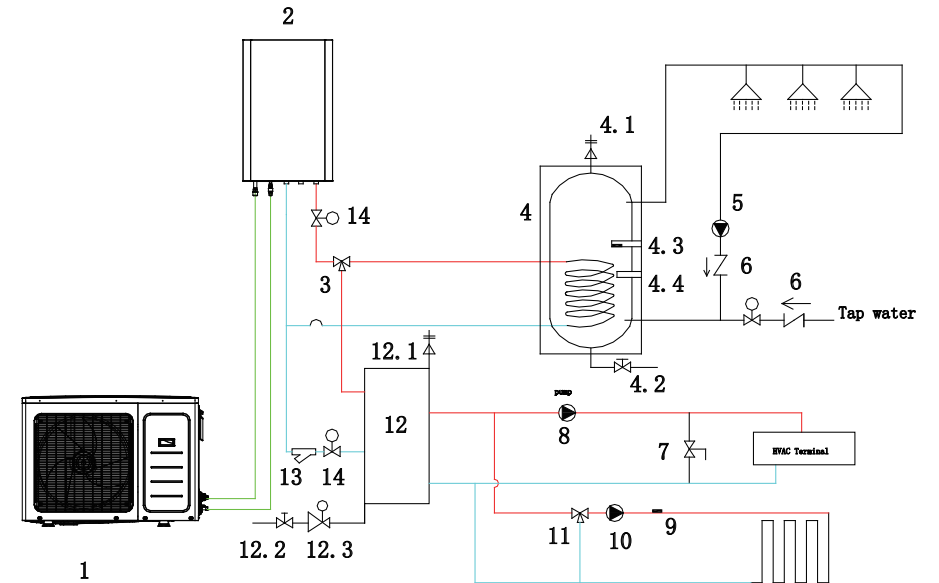

Number	Name	Number	Name
1	Outdoor unite	8	Terminal Circulating Water Pump (Field supply)
2	Indoor unite	9	2nd Temperature Zone Sensor(Accessory)
3	3-way valve (Field supply)	10	2nd Temperature ZoneCirculating Water Pump (Field supply)
4	Domestic hot water tank (Field supply)	11	Mixing valve (Field supply)
4.1	Automatic bleed valve (Field supply)	12	Balance tank (Field supply)
4.2	Drainage valve (Field supply)	12.1	Automatic Air Relief Valve (Field supply)
4.3	Hot Water Temperature Sensor (Accessory)	12.2	Drainage valve (Field supply)
4.4	Hot Water Electric Heater (Field supply)	12.3	Auto Water-supply Valve (Field supply)
5	DHW pipe pump DHW Circulating Water Pump (Field supply)	13	Filter (Accessory)
6	Check valve (Field supply)	14	Shut-off valve Stop Valve (Field supply)
7	Differential Pressure Bypass Valve		

Remark:

1.This example is only for application description, please confirm the exact installation method according to the actual situation of the user.

2.After the installation of the unit is completed, it is necessary to set the corresponding dial switch on the control panel of the indoor unit to ensure that the fuctions of hot water and the hot water electric heater can be used correctly.

The specific dial switch is shown below:

Dial Switch Name	SW2-1	SW2-2	SW2-3	SW2-4	SW2-5	SW2-6
Function	Hot Water	Solar Energy	Boiler Hot Water	Boiler Heating	Simultaneous Space Heating&Hot Water	Hot Water Electric Heater
Dial Swtich	ON	OFF	OFF	OFF	OFF	ON
Note	ON: indicates startup, OFF: indicates shutdown					

3. After the domestic hot water tank is used for a period of time, bacteria will grow inside of the tank. In order to ensure water safety, the unit has the function of manually and automatically sterilizing the domestic hot water tank. The temperature of hot water required for sterilization is higher than the temperature that the unit can achieve through heat pump heating, so the domestic hot water tank must be equipped with auxiliary electric heater.

4. The temperature sensor in the 2nd temperature zone is recommended to be placed indoors, and the operation of the water pump in the second temperature zone is controlled according to the indoor temperature. If it is placed on the outlet pipe, when the outlet water temperature of the mixing valve is greater than or equal to the set temperature of the 2nd temperature zone + 1 °C, the water pump in the 2nd temperature zone will be turned on/off periodically, and the indoor temperature cannot be rise quickly. When the water outlet temperature of the mixing valve is lower than the set temperature of the 2nd temperature zone -1 °C, the water pump of the 2nd temperature zone will always be turned on.

5. The three-way valve ( 3 ) needs to use three wires and one control, in which two wires are connected to the live wire and the neutral wire respectively, and the third wire is the control wire. The control wire is powered off when heating space, and powered on when heating water. Therefore, please pay attention to the direction of the joints when installing the three-way valve.

6. Unit has pressure switch ( 0.3 ± 0.3 bar switch open, 0.8 ± 0.3 bar switch closed ), in order to avoid the leakage of the water system resulting in insufficient water pressure, insufficient water flow, etc., which will cause the indoor electric heating to be turned off or the unit to shut down due to failure, please install the automatic water-supply valve (12.3 ) when installing the system. At the same time, please keep the water pressure of the water system between 1.2 bar and 2.0 bar when debugging the system , and ensure that the water pressure switch is closed.

## 2.4 Heat pump & boiler system

### Application 1

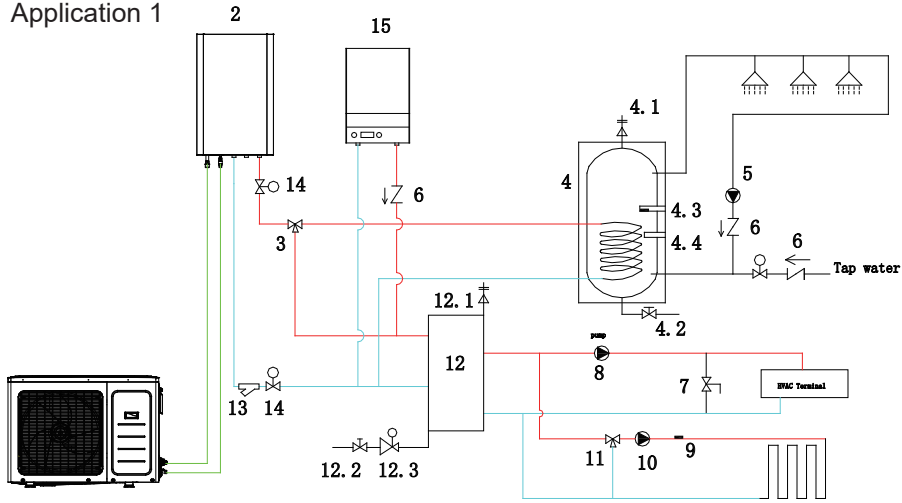

1

Number	Name	Number	Name
1	Outdoor unite	8	Terminal Circulating Water Pump (Field supply)
2	Indoor unite	9	2nd Temperature Zone Sensor(Accessory)
3	3-way valve (Field supply)	10	2nd Temperature ZoneCirculating Water Pump (Field supply)
4	Domestic hot water tank (Field supply)	11	Mixing valve (Field supply)
4.1	Automatic bleed valve (Field supply)	12	Balance tank (Field supply)
4.2	Drainage valve (Field supply)	12.1	Automatic Air Relief Valve (Field supply)
4.3	Hot Water Temperature Sensor (Accessory)	12.2	Drainage valve (Field supply)
4.4	Hot Water Electric Heater (Field supply)	12.3	Auto Water-supply Valve (Field supply)
5	DHW pipe pump DHW Circulating Water Pump (Field supply)	13	Filter (Accessory)
6	Check valve (Field supply)	14	Shut-off valve Stop Valve (Field supply)
7	Differential Pressure Bypass Valve	15	Boiler (Field supply)

Remark:

1. This example is only for application description, please confirm the exact installation method according to the actual situation of the user.
2. After the installation of the unit is completed, it is necessary to set the corresponding dial switch on the control panel of the indoor unit to ensure that the functions of hot water, hot water electric heater, boiler heating, and simultaneous space heating and hot water heating can be used correctly.

Dial Switch Name	SW2-1	SW2-2	SW2-3	SW2-4	SW2-5	SW2-6
Function	Hot Water	Solar Energy	Boiler Hot Water	Boiler Heating	Simultaneous Space Heating & Hot Water	Hot Water Electric Heater
Dial Switch	ON	OFF	OFF	ON	ON	ON
Note	ON: indicates startup, OFF: indicates shutdown					

3. After the domestic hot water tank is used for a period of time, bacteria will grow inside of the tank. In order to ensure water safety, the unit has the function of manually and automatically sterilizing the domestic hot water tank. The temperature of hot water required for sterilization is higher than the temperature that the unit can achieve through heat pump heating, so the domestic hot water tank must be equipped with auxiliary electric heater.
4. The temperature sensor in the 2nd temperature zone is recommended to be placed indoors, and the operation of the water pump in the second temperature zone is controlled according to the indoor temperature. If it is placed on the outlet pipe, when the outlet water temperature of the mixing valve is greater than or equal to the set temperature of the 2nd temperature zone + 1 °C, the water pump in the 2nd temperature zone will be turned on/off periodically, and the indoor temperature cannot rise quickly. When the water outlet temperature of the mixing valve is lower than the set temperature of the 2nd temperature zone - 1 °C, the water pump of the 2nd temperature zone will always be turned on.
5. The boiler should have its own water pump. When the host gives the boiler an active start signal, the boiler should automatically turn on the water pump and perform heating operation. When the host gives the boiler an active stop signal, the boiler should stop heating and stop the operation of its own water pump.
6. The three-way valve ( 3 ) needs to use three wires and one control, in which two wires are connected to the live wire and the neutral wire respectively, and the third wire is the control wire. The control wire is powered off when heating space, and powered on when heating water. Therefore, please pay attention to the direction of the joints when installing the three-way valve.
7. Unit has pressure switch ( 0.3 ± 0.3 bar switch open, 0.8 ± 0.3 bar switch closed ), in order to avoid the leakage of the water system resulting in insufficient water pressure, insufficient water flow, etc., which will cause the indoor electric heating to be turned off or the unit to shut down due to failure, please install the automatic water-supply valve (12.3 ) when installing the system. At the same time, please keep the water pressure of the water system between 1.2 bar and 2.0 bar when debugging the system, and ensure that the water pressure switch is closed.

## Application 2

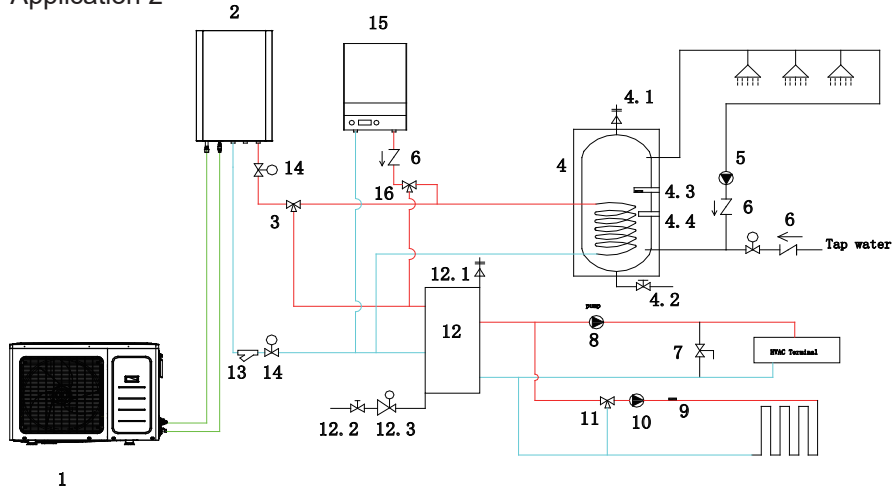

Number	Name	Number	Name
1	Outdoor unite	8	Terminal Circulating Water Pump (Field supply)
2	Indoor unite	9	2nd Temperature Zone Sensor(Accessory)
3	3-way valve (Field supply)	10	2nd Temperature Zone Circulating Water Pump (Field supply)
4	Domestic hot water tank (Field supply)	11	Mixing valve (Field supply)
4.1	Automatic bleed valve (Field supply)	12	Balance tank (Field supply)
4.2	Drainage valve (Field supply)	12.1	Automatic Air Relief Valve (Field supply)
4.3	Hot Water Temperature Sensor (Accessory)	12.2	Drainage valve (Field supply)
4.4	Hot Water Electric Heater (Field supply)	12.3	Auto Water-supply Valve (Field supply)
5	DHW pipe pump DHW Circulating Water Pump (Field supply)	13	Filter (Accessory)
6	Check valve (Field supply)	14	Shut-off valve Stop Valve (Field supply)
7	Differential Pressure Bypass Valve	15	Boiler (Field supply)
		16	Boiler Three-way Valve (Field supply)

### Remark:

1. This example is only for application description, please confirm the exact installation method according to the actual situation of the user.
2. After the installation of the unit is completed, it is necessary to perform corresponding dial settings on the control panel of the indoor unit to ensure that the functions of hot water, hot water electric heater, boiler heating, and boiler hot water can be used correctly.

Dial Switch Name	SW2-1	SW2-2	SW2-3	SW2-4	SW2-5	SW2-6
Function	Hot Water	Solar Energy	Boiler Hot Water	Boiler Heating	Simultaneous Space Heating & Hot Water	Hot Water Electric Heater
Dial Switch	ON	OFF	ON	ON	OFF	ON
Note	ON: indicates startup, OFF: indicates shutdown					

3. After the domestic hot water tank is used for a period of time, bacteria will grow inside of the tank. In order to ensure water safety, the unit has the function of manually and automatically sterilizing the domestic hot water tank. The temperature of hot water required for sterilization is higher than the temperature that the unit can achieve through heat pump heating, so the domestic hot water tank must be equipped with auxiliary electric heater.

4. The temperature sensor in the 2nd temperature zone is recommended to be placed indoors, and the operation of the water pump in the second temperature zone is controlled according to the indoor temperature. If it is placed on the outlet pipe, when the outlet water temperature of the mixing valve is greater than or equal to the set temperature of the 2nd temperature zone + 1 °C, the water pump in the 2nd temperature zone will be turned on/off periodically, and the indoor temperature cannot be rise quickly. When the water outlet temperature of the mixing valve is lower than the set temperature of the 2nd temperature zone -1 °C, the water pump of the 2nd temperature zone will always be turned on.

5. The boiler should have its own water pump. When the host gives the boiler an active start signal, the boiler should automatically turn on the water pump and perform heating operation. When the host gives the boiler an active stop signal, the boiler should stop heating and stop the operation of its own water pump.

6. The three-way valve ( 3 ) and the boiler three-way valve ( 16 ) need to use three wires and one control, in which two wires are connected to the live wire and the neutral wire respectively, and the third wire is the control wire. The control wire is powered off when heating space, and powered on when heating water. Therefore, please pay attention to the direction of the joints when installing the three-way valve.

7. The control of the three-way valve ( 16 ) of the boiler should be synchronized with that of the three-way valve ( 3 ), which is both of the three-way valves power on or off at the same time.

8. Unit has pressure switch ( 0.3 ± 0.3 bar switch open, 0.8 ± 0.3 bar switch closed ), in order to avoid the leakage of the water system resulting in insufficient water pressure, insufficient water flow, etc., which will cause the indoor electric heating to be turned off or the unit to shut down due to failure, please install the automatic water-supply valve ( 12.3 ) when installing the system. At the same time, please keep the water pressure of the water system between 1.2 bar and 2.0 bar when debugging the system, and ensure that the water pressure switch is closed.

### Application 3

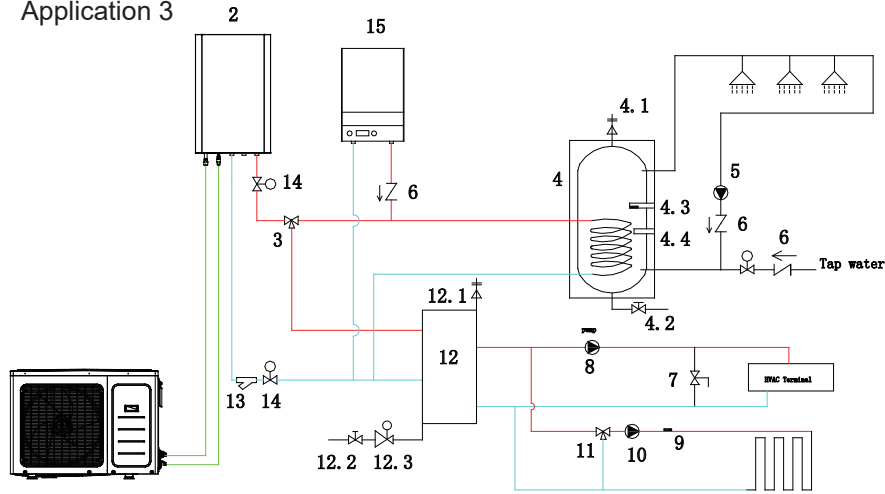

1

Number	Name	Number	Name
1	Outdoor unite	8	Terminal Circulating Water Pump (Field supply)
2	Indoor unite	9	2nd Temperature Zone Sensor(Accessory)
3	3-way valve (Field supply)	10	2nd Temperature Zone Circulating Water Pump (Field supply)
4	Domestic hot water tank (Field supply)	11	Mixing valve (Field supply)
4.1	Automatic bleed valve (Field supply)	12	Balance tank (Field supply)
4.2	Drainage valve (Field supply)	12.1	Automatic Air Relief Valve (Field supply)
4.3	Hot Water Temperature Sensor (Accessory)	12.2	Drainage valve (Field supply)
4.4	Hot Water Electric Heater (Field supply)	12.3	Auto Water-supply Valve (Field supply)
5	DHW pipe pump DHW Circulating Water Pump (Field supply)	13	Filter (Accessory)
6	Check valve (Field supply)	14	Shut-off valve Stop Valve (Field supply)
7	Differential Pressure Bypass Valve	15	Boiler (Field supply)

Remark:

- This example is only for application description, please confirm the exact installation method according to the actual situation of the user.
- After the installation of the unit is completed, it is necessary to set the corresponding dial switch on the control panel of the indoor unit to ensure that the functions of hot water, hot water electric heater, and boiler hot water can be used correctly.

Dial Switch Name	SW2-1	SW2-2	SW2-3	SW2-4	SW2-5	SW2-6
Function	Hot Water	Solar Energy	Boiler Hot Water	Boiler Heating	Simultaneous Space Heating & Hot Water	Hot Water Electric Heater
Dial Switch	ON	OFF	ON	OFF	OFF	ON
Note	ON: indicates startup, OFF: indicates shutdown					

- After the domestic hot water tank is used for a period of time, bacteria will grow inside of the tank. In order to ensure water safety, the unit has the function of manually and automatically sterilizing the domestic hot water tank. The temperature of hot water required for sterilization is higher than the temperature that the unit can achieve through heat pump heating, so the domestic hot water tank must be equipped with auxiliary electric heater.
- The temperature sensor in the 2nd temperature zone is recommended to be placed indoors, and the operation of the water pump in the second temperature zone is controlled according to the indoor temperature. If it is placed on the outlet pipe, when the outlet water temperature of the mixing valve is greater than or equal to the set temperature of the 2nd temperature zone + 1 °C, the water pump in the 2nd temperature zone will be turned on/off periodically, and the indoor temperature cannot rise quickly. When the water outlet temperature of the mixing valve is lower than the set temperature of the 2nd temperature zone -1 °C, the water pump of the 2nd temperature zone will always be turned on.
- The boiler should have its own water pump. When the host gives the boiler an active start signal, the boiler should automatically turn on the water pump and perform heating operation. When the host gives the boiler an active stop signal, the boiler should stop heating and stop the operation of its own water pump.
- The three-way valve ( 3 ) and the boiler three-way valve ( 16 ) need to use three wires and one control, in which two wires are connected to the live wire and the neutral wire respectively, and the third wire is the control wire. The control wire is powered off when heating space, and powered on when heating water. Therefore, please pay attention to the direction of the joints when installing the three-way valve.
- The control of the three-way valve ( 16 ) of the boiler should be synchronized with that of the three-way valve ( 3 ), which is both of the three-way valves power on or off at the same time.
- Unit has pressure switch ( 0.3 ± 0.3 bar switch open, 0.8 ± 0.3 bar switch closed ), in order to avoid the leakage of the water system resulting in insufficient water pressure, insufficient water flow, etc., which will cause the indoor electric heating to be turned off or the unit to shut down due to failure, please install the automatic water-supply valve ( 12.3 ) when installing the system. At the same time, please keep the water pressure of the water system between 1.2 bar and 2.0 bar when debugging the system, and ensure that the water pressure switch is closed.

## 2.5 Solar energy hot water system

### Application 1:

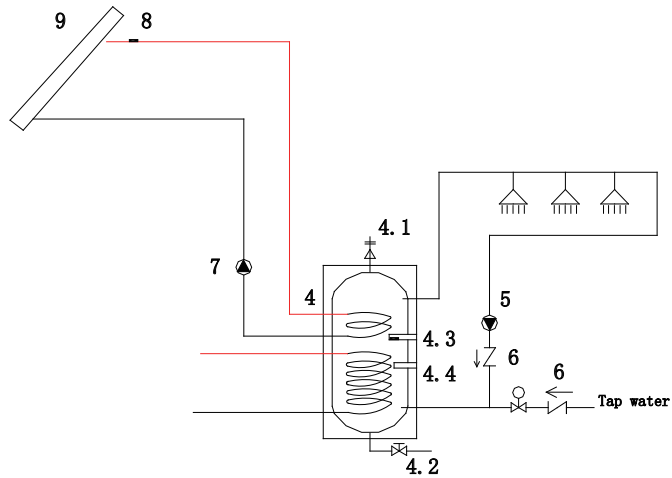

number	name	number	name
4	Domestic hot water tank (Field supply)	7	Solar Panel Hot Water Circulating Pump (Field supply)
4.1	Automatic bleed valve (Field supply)	8	Solar Panel Leaving Water Temperature Sensor (Accessory)
4.2	Drainage valve (Field supply)	9	Solar Panel
4.3	Hot Water Temperature Sensor (Accessory)		
4.4	Hot Water Electric Heater (Field supply)		
5	DHW pipe pump (Field supply)		
6	Check valve (Field supply)		

#### Remark:

1. This example is only used to explain the application of solar auxiliary heating. For other applications, please confirm the exact installation method according to the actual situation of the user.
2. After the installation of the unit is completed, it is necessary to set the corresponding dial switch on the control panel of the indoor unit to ensure that the functions of hot water, hot water electric heater, and solar hot water can be used correctly.

Dial Switch Name	SW2-1	SW2-2	SW2-3	SW2-4	SW2-5	SW2-6
Function	Hot Water	Solar Energy	Boiler Hot Water	Boiler Heating	Simultaneous Space Heating & Hot Water	Hot Water Electric Heater
Dial Switch	ON	ON	Dial Switch according to actual installation			ON
Note	ON: indicates startup, OFF: indicates shutdown					

3. After the domestic hot water tank is used for a period of time, bacteria will grow inside of the tank. In order to ensure water safety, the unit has the function of manually and automatically sterilizing the domestic hot water tank. The temperature of hot water required for sterilization is higher than the temperature that the unit can achieve through heat pump heating, so the domestic hot water tank must be equipped with auxiliary electric heater.

### Application 2:

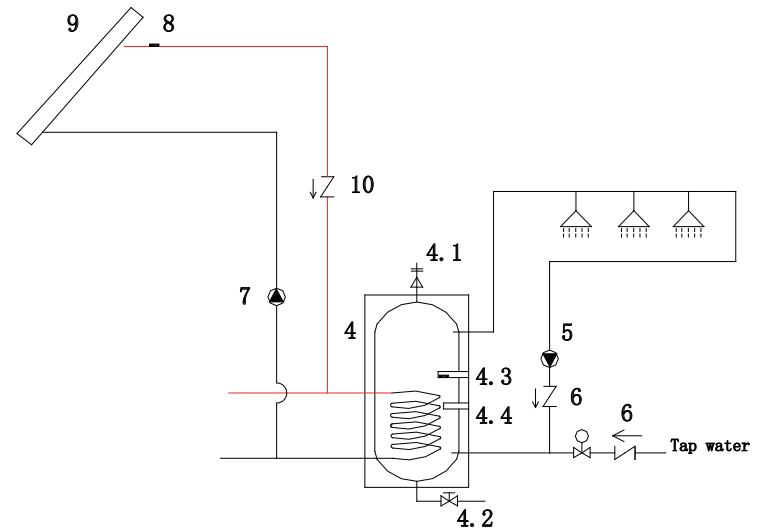

number	name	number	name
4	Domestic hot water tank (Field supply)	7	Solar Panel Hot Water Circulating Pump (Field supply)
4.1	Automatic bleed valve (Field supply)	8	Solar Panel Leaving Water Temperature Sensor (Accessory)
4.2	Drainage valve (Field supply)	9	Solar Panel
4.3	Hot Water Temperature Sensor (Accessory)	10	Check valve (Field supply)
4.4	Hot Water Electric Heater (Field supply)		
5	DHW pipe pump (Field supply)		
6	Check valve (Field supply)		

Remark:

1. This example is only used to explain the application of solar auxiliary heating. For other applications, please confirm the exact installation method according to the actual situation of the user.
2. After the installation of the unit is completed, it is necessary to set the corresponding dial switch on the control panel of the indoor unit to ensure that the functions of hot water, hot water electric heater and solar hot water can be used correctly.

Dial Switch Name	SW2-1	SW2-2	SW2-3	SW2-4	SW2-5	SW2-6
Function	Hot Water	Solar Energy	Boiler Hot Water	Boiler Heating	Simultaneous Space Heating&Hot Water	Hot Water Electric Heater
Dial Switch	ON	ON	Dial Switch according to actual installation			ON
Note	ON: indicates startup, OFF: indicates shutdown					

3. After the domestic hot water tank is used for a period of time, bacteria will grow inside of the tank. In order to ensure water safety, the unit has the function of manually and automatically sterilizing the domestic hot water tank. The temperature of hot water required for sterilization is higher than the temperature that the unit can achieve through heat pump heating, so the domestic hot water tank must be equipped with auxiliary electric heater.

## Installation

### 3.1 Instructions

#### Inspection

Follow these steps to check before installation to ensure smooth installation.

1. Remove the packaging, check whether the unit nameplate is consistent with the order. Check whether there are scratches, deformation and other defects on the unit surface. Check whether the accessories are complete according to the packing list inside the box. If you have questions, please contact the carrier and your local dealer to confirm. If possible, take photographs of the scene as evidence.
2. Check the site if there is enough space for installation and maintenance.
3. Warning! During installation and maintenance, the power supply must be cut off, in case that there will be danger of electric shock!
4. Make sure the power is consistent with the requirements of the product nameplate, power, and safety switch should be able to withstand the maximum operating current.
5. Unit power cord must be connected to mains power through the circuit breaker of sufficient capacity.
6. The unit should be grounded.
7. All connected wires and cables must comply with the relevant national and local standards.

#### Lifting

The unit should maintain a balance during lifting, otherwise it may cause damage to the unit, and may cause injury.



## Vacuum

1. Connect the liquid charging pipe wearing a thimble to the filling mouth of the shut-off valve and vacuum pump, then start the vacuum pump until the air inside the pipe is drained (at least 30 minutes of vacuum time), then the pressure gauge shows -1bar;
2. Shut off the valve on the pressure gauge;
3. Loosen the shut-off valve on the gas pipe and liquid pipe with a hex wrench;
4. Take leakage test to all connection joints with halogen leak detector or soapy water;
5. Screw on the bonnet and fasten with a wrench.

## Attention!

Beachten Sie, dass der Prüfort gut belüftet sein sollte. Es ist möglich, giftige Gase zu erzeugen, wenn Kältemittelleck das Feuer und Wasser trifft.

Stellen Sie sicher, dass nach Abschluss der Installation kein Kältemittel austritt. Wenn das ausgetretene Kältemittel auf Herde, Gaswarmwasserbereiter, Elektroheizungen oder andere Wärmequellen trifft, können giftige Gase entstehen.

## 3.2 Safety rules

The outdoor unit should be installed in a well ventilated place to ensure the inlet and outlet without any block.

The installation location for outdoor and indoor should be easily drained.

Installation base of stand should be strong enough to ensure the unit maintains level and can withstand the running weight.

Ensure the unit is mounted horizontally.

Do not install the unit in places which easily gather pollution, corrosive gases and gray sand, leaves and other contaminants.

Installation location should not close to flammable, explosive and fire place.

Installation site must be a floor, mounting pad or foundation.

The indoor unit should be placed within the room temperature 5-43 °C, the sides and top of the unit should have enough space to carry out routine maintenance work.

The pipe should have firmly support independent of the heat unit, avoiding stress on the unit parts.

For easy routine maintenance, pressure gauge with a cock and shut-off valve can be installed on the supply pipe and return pipe, as close to the unit as possible.

## 3.3 Transport and storage

Be careful to move the indoor and outdoor unit. It needs the help of other installers. And also be careful of sharp edges or fins on the heat pump in case it scratches your fingers when handling.

Must keep the heat pump upright and dry during transport or storage.

Consider the size and weight of the heat pump.

### 3.4 Installation Cautions

----Precautions before the installation

- The installation should be carried out by professional installer.
- Before the installation, please do the purchase of installation materials according to the requirement in advance. Important materials needed during installation, such as cables, leakage protectors, air switch and so on should be selected according to the machine technical requirements. And other accessories such as distribution box, threading pipe, fixed parts, insulation materials, water fittings, etc., can be selected according to local specifications.
- This heat pump is with specific power supply cable, Make sure that the ground line is properly earthed.
- The installation solution should be safe, reliable, economic. Mark and identify different pipes, valves.
- If the machine is installed in a location which with dust crumbs, heavy oil fumes, wet environment, or the installation could not be completed in 5 days, you must take appropriate protective measures, such as wrapping the machine with plastic sheeting.
- Please install in strict accordance with the instructions, your national and local air conditioning/heat pump constructions.
- The power supply must be consistent with the unit nameplate. The maximum deviation of the power supply voltage shall not exceed 10%.

--- Installation environment

- During installation, enough space should be left around the outdoor unit for further maintenance purpose;

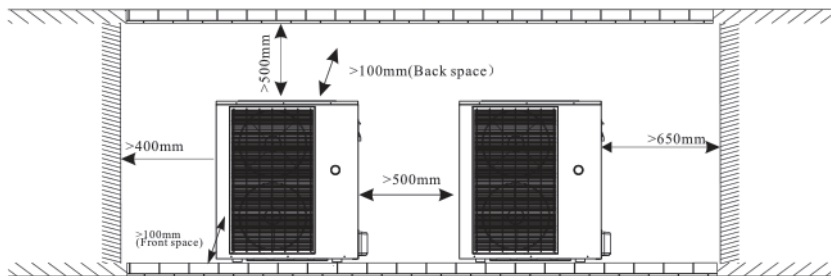

- When the air inlet and outlet are free of obstacles, but the upper part of the outdoor unit has an obstacle, please keep the obstacle 2 meters away from it. If the machine is with sideward air exhaust, please pay attention to monsoon effect, air exhaust direction should out of monsoon direction.
- The exhaust duct should be installed when the exhaust requirements are not met.
- Avoid installing in damp and uneven places, and shall keep away from places which with excessive heat sources, combustibles, corrosive gases, strong electric magnetic fields, much dust, heavy sand and soot.
- The supporting surface for the machine should be flat and the installation position can bear the weight of the unit, so as to decrease noise and vibration.
- Weather enclosure is necessary if outdoor unit is installed outside;
- Please ensure there is drainage system around the location, to drain the condensate water when defrosting;
- Please install outdoor unit far away from the exhaust port of kitchen to avoid oil smoke entering into outdoor heat exchanger;

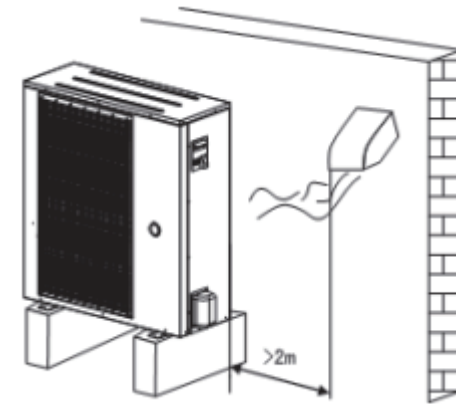

## NOTE:

The bottom of the outdoor unit needs to add a cushion to absorb the shock. There are 4 cushioning pads and put in the accessory bag of the outdoor unit.

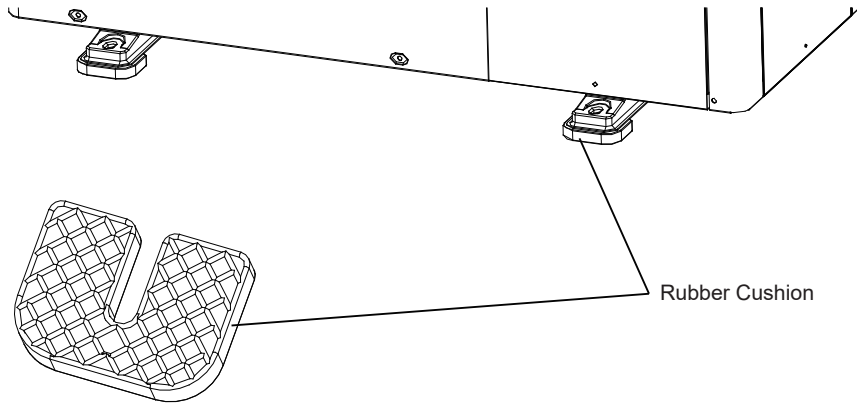

- The indoor unit should be hang on the wall and keep the water connector downwards;

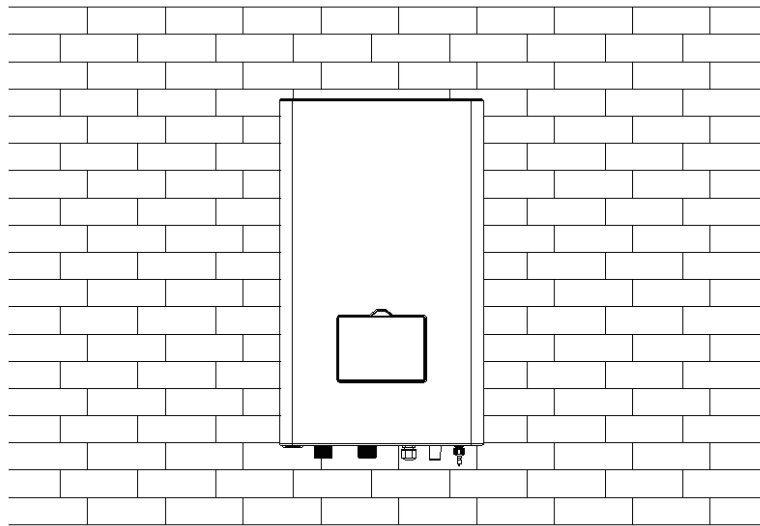

## ---Machine Installation

### ●Outdoor unit installation

User can either use the dedicated mounting bracket from the supplier, or prepare a suitable bracket for the unit installation. Make sure the installation meets following requirements:

1. The unit must be installed on flat concrete blocks, or a dedicated mounting bracket. The bracket should be able to support at least 5 times of unit's weight.
2. All nuts must be tightened after the bracket is fixed; otherwise, it may cause damage to the equipment;
3. User should double check and make sure the installation of unit is firm enough.
4. The bracket can be of stainless steel, galvanized steel, aluminum and other materials as required by the user.
5. Besides the mounting bracket, the user can also install the outdoor unit on two concrete blocks, or a raised concrete platform. Please make sure that the unit is securely fastened after installation.
6. Please refer the dimension of outdoor unit when choose a suitable wall bracket .

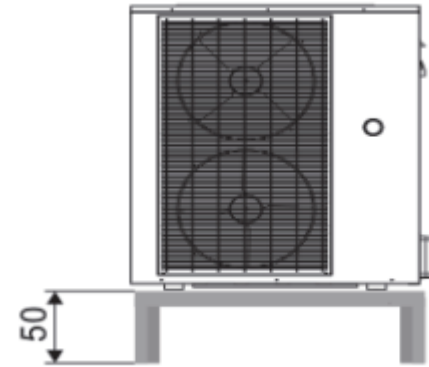

### 3.5 Installation space

Above shows the indoor and outdoor unit dimensions and foot fixed location.

Outdoor unit

Unit: mm

#### 3.5.1 AHbS4VR3H/O, AHbS6VR3H/O

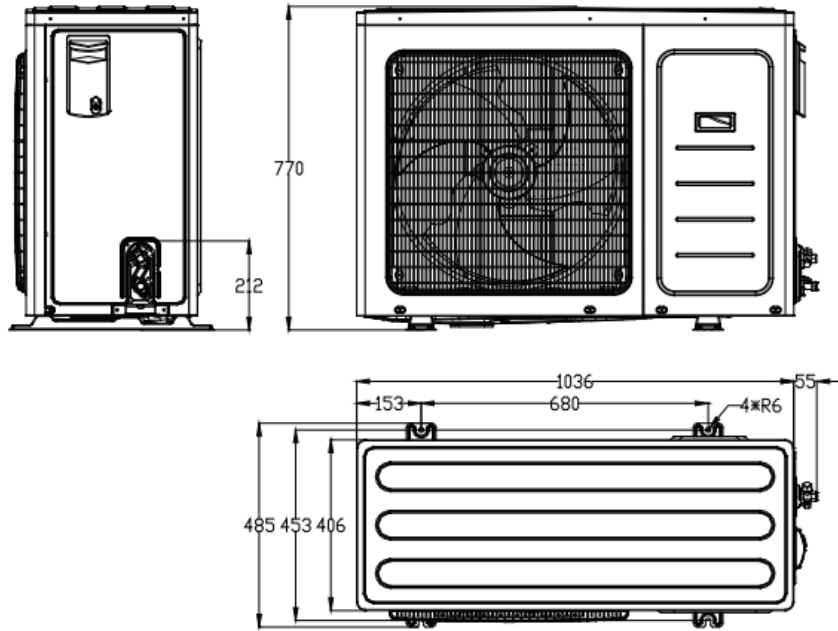

#### 3.5.2 AHbS8VR3H/O, AHbS10VR3H/O, AHbS12VR3H/O, AHbS14VR3H/O, AHbS16VR3H/O AHbS12VR3X/O, AHbS14VR3X/O, AHbS16VR3X/O

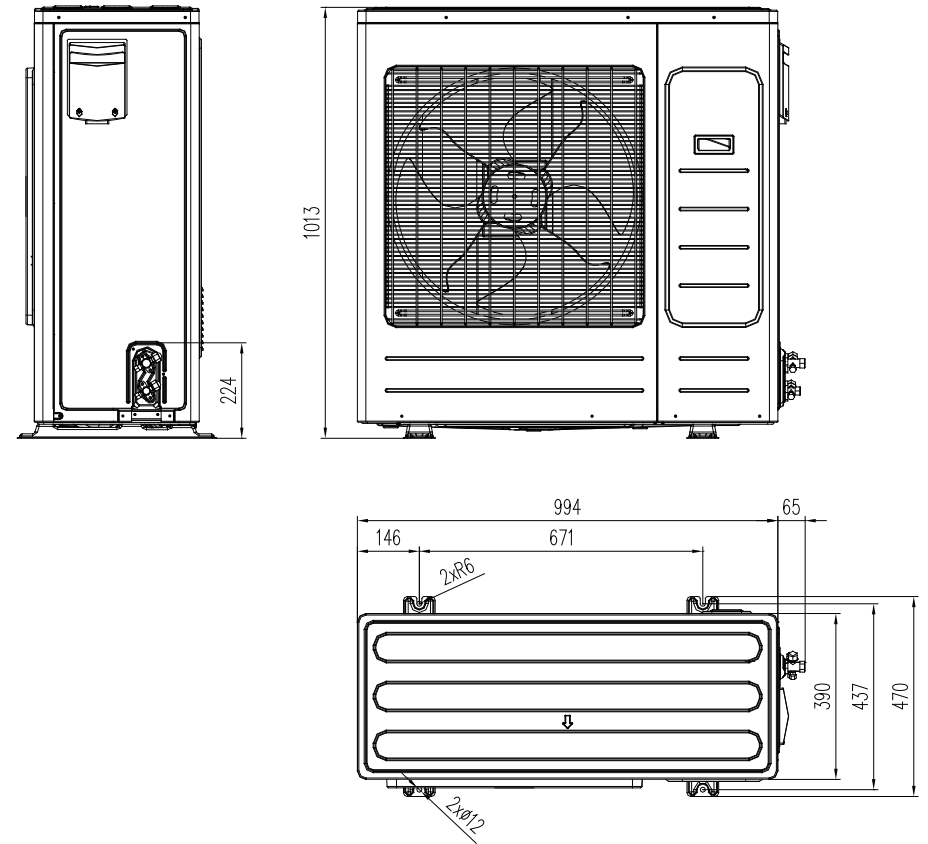

### Outdoor unit

Unit: mm

#### 3.5.3 AHbS6VR3H/IP, AHbS10VR3H/IP, AHbS16VR3H/IP, AHbS16VR3X/IP

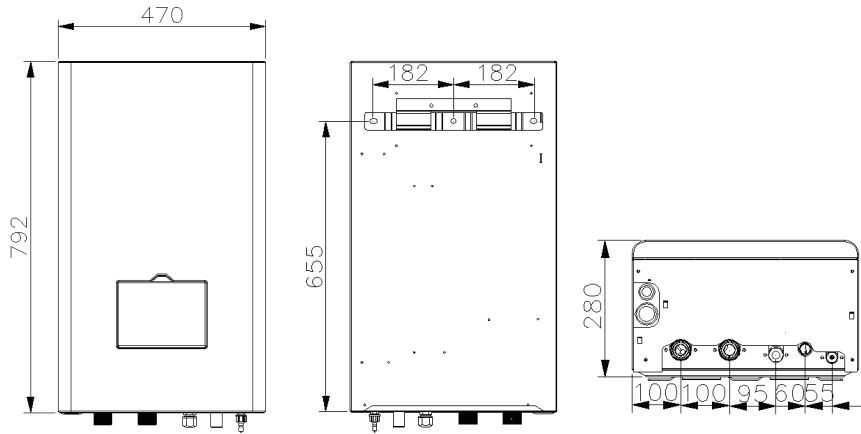

Above shows the minimum space of installation and maintenance for indoor unit.

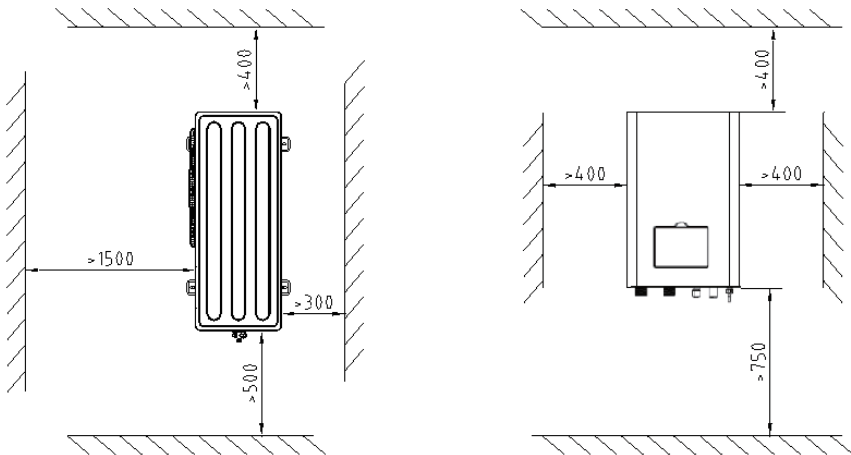

### How to install the indoor unit

First step: Remove the front cover panel, as shown the below picture.

1.1 Open the wired controller's cover plate which under the front panel of the indoor unit, you can see the pressure gauge and the wired controller. The cover plate can be opened by slight prying since it only fixed with a magnet. Do not use brute force, which may damage this panel.

1.2 Open the cover plate and remove the two fixing screws

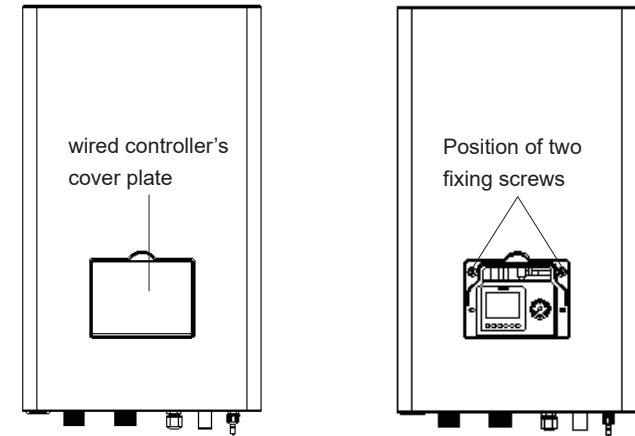

1.3 After removing the screws, as shown in the picture below, lift the front panel upwards to remove it.

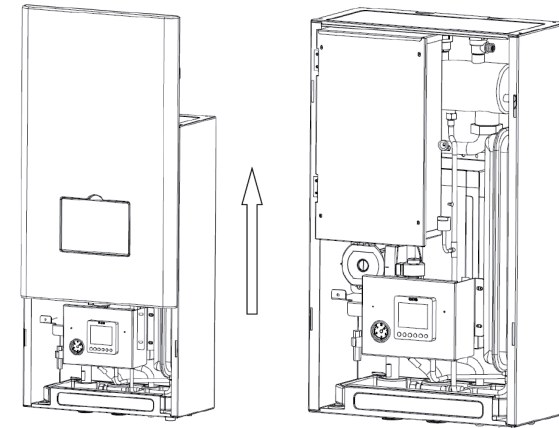

Second step: Install the bracket on the wall

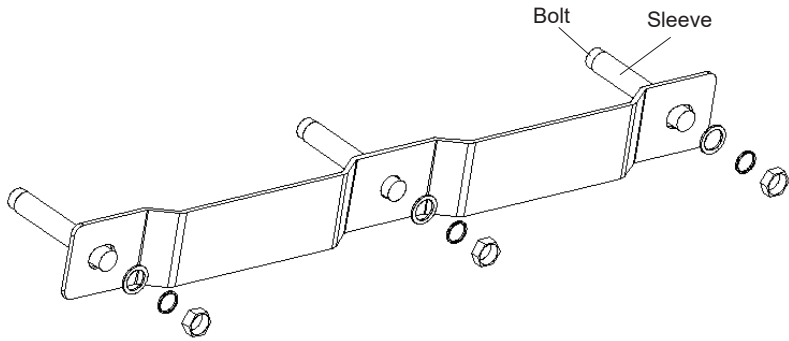

Third step: Hang the indoor unit on the wall

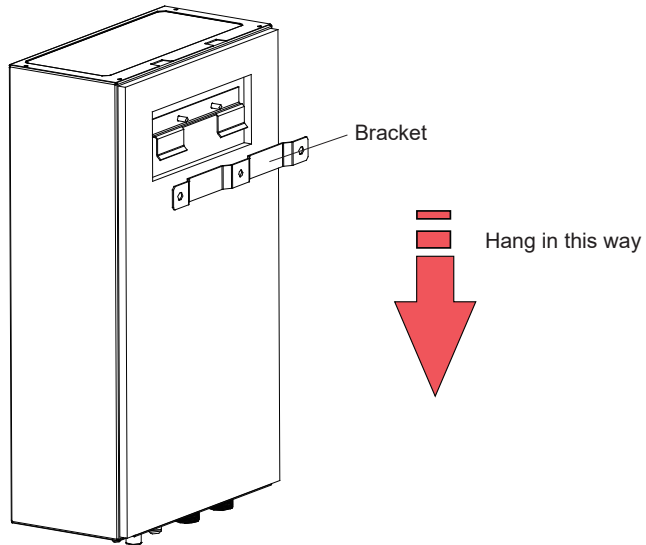

Note:

1. As the indoor unit is heavy, at least two people are required to install it.
2. Please select a wall or support that can bear at least twice the weight of the indoor unit reliably and safely.
3. Fix the mounting bracket to the wall with 3 pieces M8 or above expansion bolts with a length of more than 80mm. During installation, please ensure the levelness.
4. Ensure that the bracket installation on the wall is with good levelness. Otherwise, the air in the water circulation system will not be easily discharged, which may lead to machine failure.

Fourth step: After the power cord is connected, install the front panel as the direction shown and fix with screw.

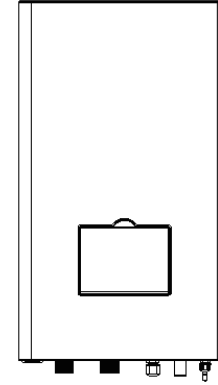

### 3.6 Water pipe connection

Water pipe connection for the indoor unit

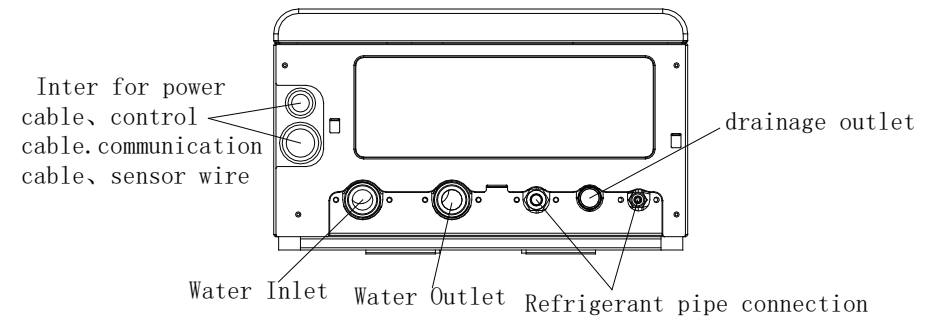

## Water pipe connection

- Please use flexible pipe connections between the unit inlet/outlet with the main water pipe to prevent shattering the connection pipe.
- It's better to use metal pipes (such as stainless steel, lined with plastic, lined with stainless steel or thin-walled brass, etc.). If the plastic pipe (such as PP-R pipe, ABS pipe, etc.) is used, it should be considered the pipe expansion issues between the unit and tank.
- Pipes shall be connected according to the system manual and constructed in accordance with the corresponding national construction standards.
- Piping installation should be smooth vertical and horizontal and piping arrangement is reasonable, to minimize bending, reduce the resistance loss of water systems as possible.
- Water leakage is not allowed in piping and joints.
- After installation of tap water supply pipe, circulation pipe between the unit and tank, the tightness pressure test should be carried out, and the sewage should be drained to make sure the system clean.

## Warning!

- The indoor unit is only applicable to the closed water system, and the ambient temperature should be within the range of 5-35 °C, otherwise the machine service life will be affected or even damaged.

## Water pipeline pressure and leak test

- After installation, pressure leak test must be carried out. The maximum water pressure of the system cannot exceed 3 bar. If the water pressure is greater than 3 bar, the indoor water circuit must be closed through the water valve, otherwise the expansion tank which fixed in the indoor unit will be damaged.
- The drain hole shall be at the lowest point of the system to drain all circulating water during system maintenance.
- The air relieve device should be at the highest point of the system to ensure that the air in the water system can be exhausted.
- The water system shall be equipped with differential pressure water supply valve, and the water pressure for normal operation of the machine is 1~2bar.

## Wire Controller installation

Method 1: Install directly on the indoor unit

1. Open the small panel of the indoor unit, and remove the rear cover of the wire controller according to the diagram on the rear cover of the wire controller.
2. Use two ST3.9\*9.5 screws to fix the rear cover of the wire controller on the wire controller bracket.
3. Pull four-core lead of the indoor unit through wire controller through the rear cover of the wire controller, then insert four-core connector into the wire controller, then fix the wire controller on the rear cover.

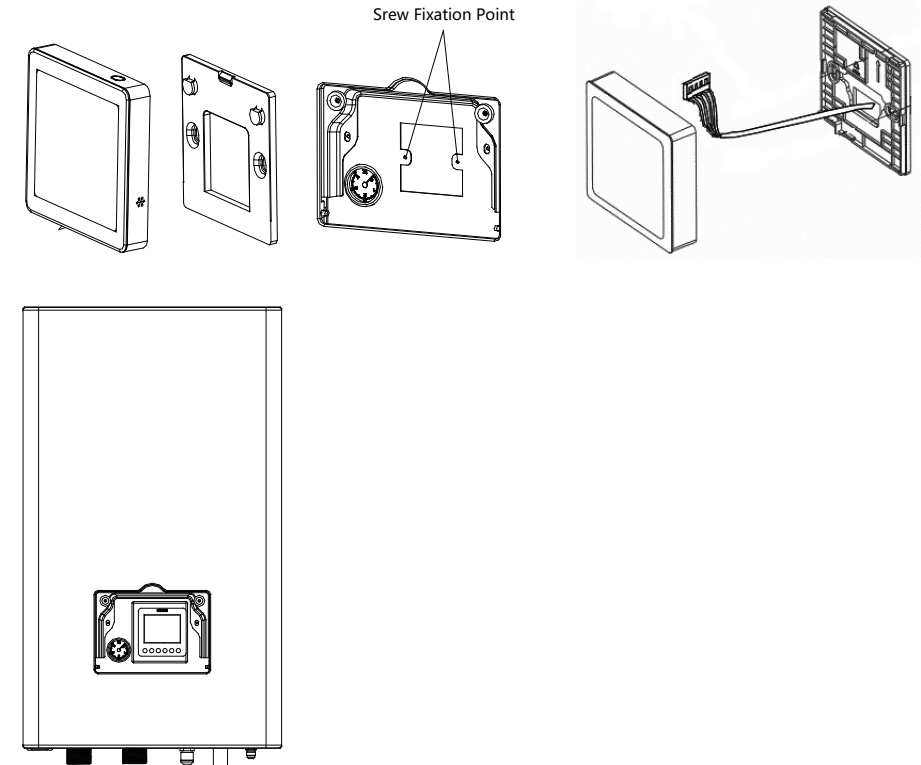



Method 2 : Install on the electrical box

- 1、 Take out the 10m wire controller communication extension cable (accessory), connect one end with the four-core lead of the wire controller of the indoor unit, and pass the other end through the electrical box
- 2、 Remove the rear cover of the wire controller according to the diagram on the rear cover of the wire controller, and then pull the communication extension cable of the remote controller through the rear cover, and then fix the wire controller on the electrical box with two M4\*10 screws (accessories);
- 3、 Insert the wire controller communication extension cable into the wire controller, and then fix the wire controller on the rear cover.

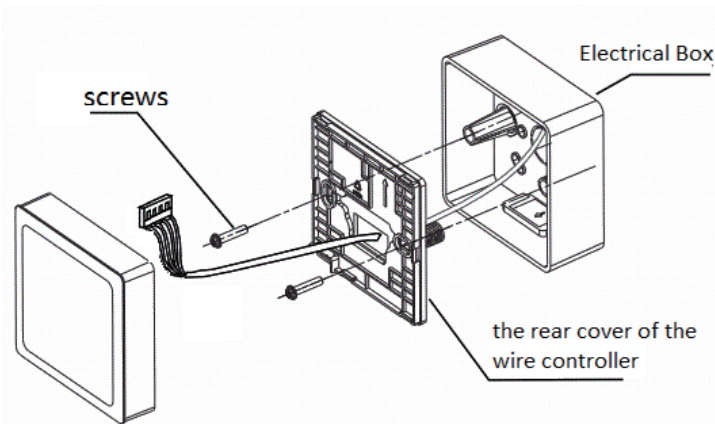

### Installation of refrigerant piping connections

- After the indoor and outdoor unit installation, the refrigerant pipe will be connected. The interior of brass pipe should be clean, without oil, impurities. Pay attention to avoid impurities into the connection pipe.

### Warning!

- This machine is using R32 flammable refrigerant, and non-removable devices must be used for connecting pipes of indoor and outdoor units. If leakage occurs due to poor connection process, please cut off and replace the connector and reconnect.

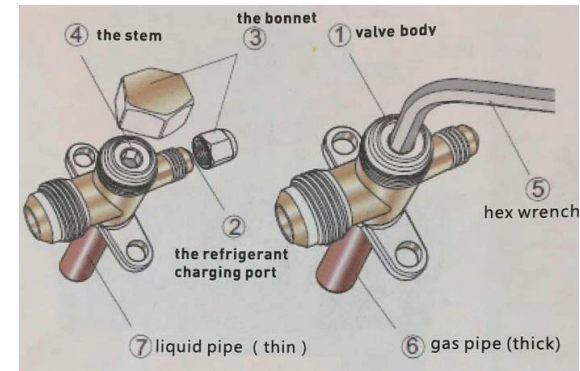

- Flared part of brass pipe should be flat and smooth. To ensure the tightness, we recommend apply a proper amount of the freezing machine oil in the brass flared part.
- It is required to tighten with two wrenches when connecting it with the brass body to prevent damage to the valve body and brass.
- To prevent heat loss and condensation dripping, after passing the leakage test, gas pipe and liquid pipe must be insulated with suitable insulation material.

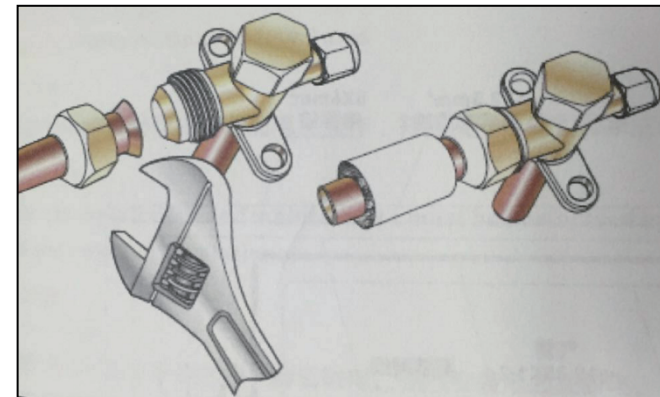

## Water pipe connection for the indoor unit Pipeline extending

The standard pipe length is 5m, designed to allow a maximum length of 20m (the largest height difference between outdoor unit and indoor unit is 15m). When the actual length of the connection pipe exceeds 5m, refrigerant oil POE.VG74 shall be charged by 20g/m of the pipe length of the excess part. See the following table for refrigerant charging amount:

Liquid measuring pipe diameter (mm)	Adding amount of refrigerant ( Kg/m )
6.35	0.018
9.52	0.035

When the indoor and outdoor unit height gap exceeds 6m, the bend for oil returning should be set every 5m height. The bend for oil returning is shown below.

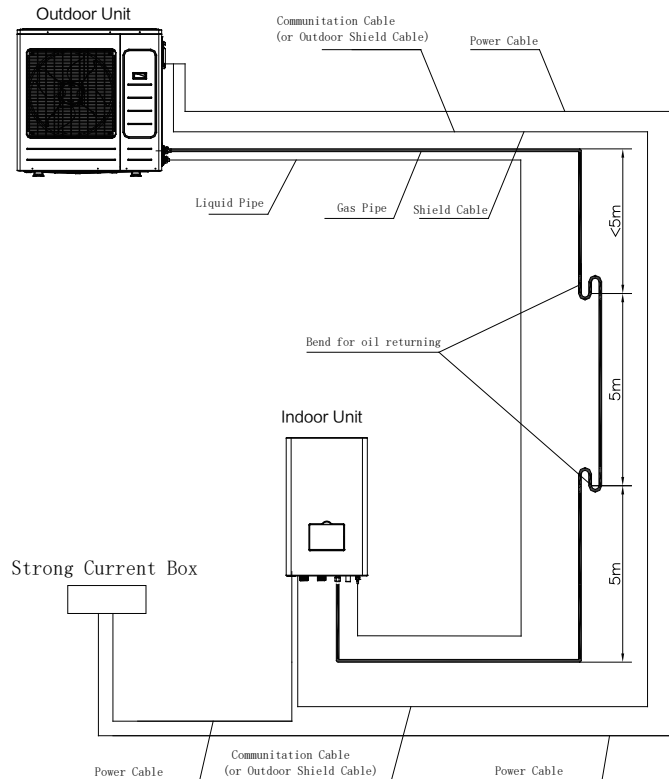

## Production drawings for the bend for oil returning

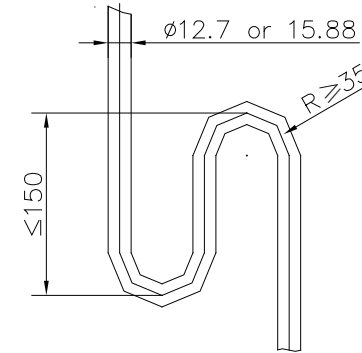

## 3.7 Electrical Installation

### Important information / Safety Rules

#### NOTE!

Electrical installation and maintenance must be performed by a qualified electrician and comply with local and national regulations.

#### Danger! Caution Current

- Wiring board is charged, it's very dangerous and easy to shock. The power supply must be off before the electrical installation. According to local wire using regulations, the electrical installation must use permanent cable line.
- Use all-pole circuit breaker to cut off the power and to ensure complete disconnection in overvoltage Category III.

#### Power supply!

Variation of power supply voltage for the unit is  $\pm 6\%$ .  
Unbalanced power supply should not exceed 2%.  
The power wire shall at least fulfill the requirements of 60245 IEC 57

#### Safety switch!

All heat pumps must be equipped with a safety switch.

#### Grounding!

Heat pump needs to be grounded to prevent parts damage and shock!

### 3.8 Electrical Wiring Diagram

Connect the indoor unit terminal block and outdoor unit terminal block as shown below.

NOTE:

Before obtaining access to terminals, all supply circuits must be disconnected.

3.8.1 AHbS4VR3H/O, AHbS6VR3H/O, AHbS8VR3H/O, AHbS10VR3H/O, AHbS12VR3H/O, AHbS14VR3H/O, AHbS16VR3H/O, AHbS6VR3H/IP, AHbS10VR3H/IP, AHbS16VR3H/IP

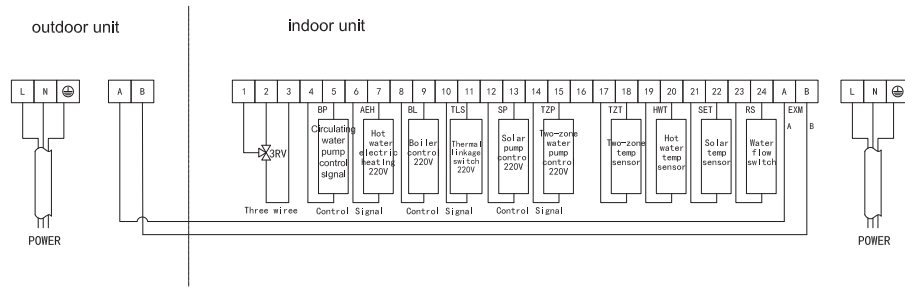

3.8.2 AHbS12VR3X/O, AHbS14VR3X/O, AHbS16VR3X/O, AHbS16VR3X/IP

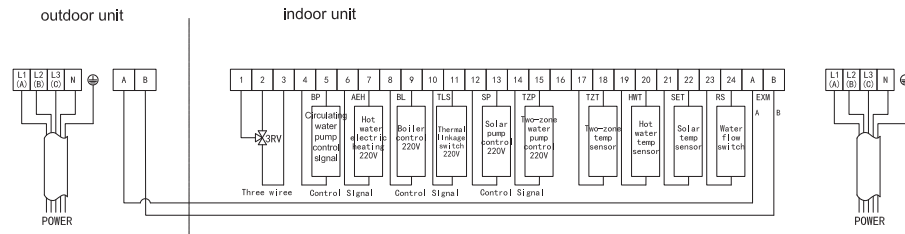

Indoor/outdoor unit connection cable (field supplied) recommended wiring specification table		
Model	Power wire	Signal wire
AHbS4VR3H/O, AHbS6VR3H/O	3*2.5mm <sup>2</sup>	2*1.0mm <sup>2</sup>
AHbS6VR3H/IP, AHbS10VR3H/IP, AHbS16VR3H/IP		
AHbS8VR3H/O, AHbS10VR3H/O	3*4mm <sup>2</sup>	
AHbS12VR3H/O, AHbS14VR3H/O, AHbS16VR3H/O	3*6mm <sup>2</sup>	
AHbS16VR3X/IP	5*2.5mm <sup>2</sup>	
AHbS12VR3X/O, AHbS14VR3X/O, AHbS16VR3X/O	5*4mm <sup>2</sup>	

Controller fuse specification table

Controller	Specification
Fan drive board	T5AH250VAC(SBF)
Indoor main PCB	T8AH250VAC(SBF)
Outdoor main PCB	T8AH250VAC(SBF)
HMD1W-20C11/HMD1W-20C12 inverter module	T25AH250VAC(SBF)
LT2173 inverter module	T30AH250VAC(SBF)

### 3.9 Wiring diagram

Indoor unit circuit diagram

AHbS6VR3H/IP, AHbS10VR3H/IP, AHbS16VR3H/IP

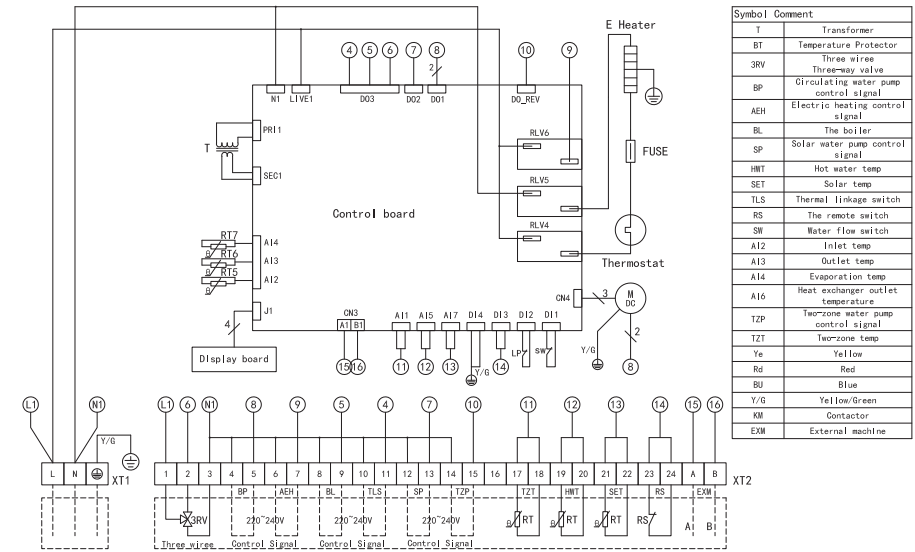

Symbol	Comment
T	Transformer
BT	Temperature Protector
3RV	Three-way valve
BP	Circulating water pump control signal
AEH	Electric heating control signal
BL	The boiler
SP	Solar water pump control signal
HWT	Hot water temp
SET	Solar temp
TLS	Thermal linkage switch
RS	The remote switch
SW	Water flow switch
AI2	Inlet temp
AI3	Outlet temp
AI4	Evaporation temp
AI6	Heat exchanger outlet temp
TZP	Two-zone water pump control signal
TZT	Two-zone temp
%	%
Rd	Red
Bl	Blue
Y/G	Yellow/Green
KN	Contactor
EXM	External machine

Note: The dial switch is selected according to the functions described in the technical manual.

### AHbS16VR3X/IP

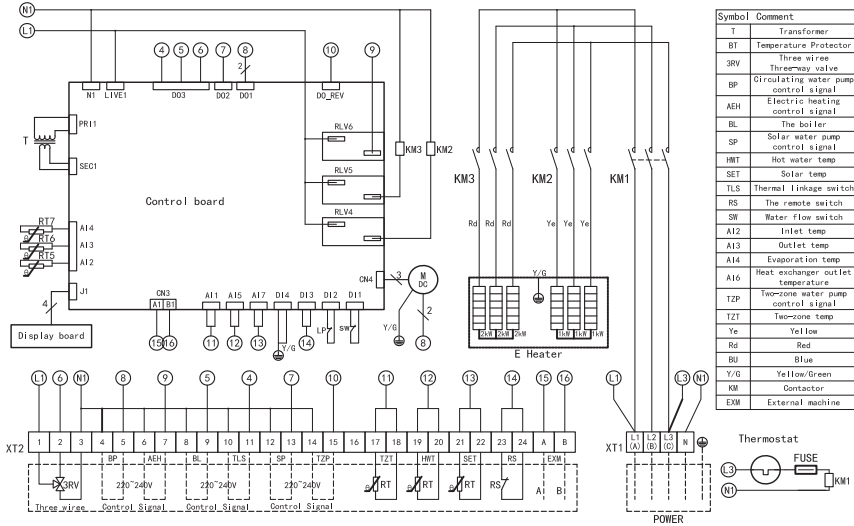

Symbol	Comment
T	Transformer
BT	Temperature Protector
3RV	Three wire Three-way valve
BP	Circulating water pump control signal
AEH	Electric heating control signal
BL	The boiler
SP	Solar water pump control signal
HNT	Hot water temp
SET	Solar temp
TLS	Thermal linkage switch
RS	The remote switch
SW	Water flow switch
AI2	Inlet temp
AI3	Outlet temp
AI4	Evaporation temp
AI6	Heat exchanger outlet temperature
TZP	Two-zone water pump control signal
TZ1	Two-zone temp
Ye	Yellow
Rd	Red
Bl	Blue
Y/G	Yellow/Green
KM	Contactor
EXM	External machine

Note: The dial switch is selected according to the functions described in the technical manual.

### Outdoor unit circuit diagram

AHbS4VR3H/O, AHbS6VR3H/O, AHbS8VR3H/O, AHbS10VR3H/O, AHbS12VR3H/O, AHbS14VR3H/O, AHbS16VR3H/O

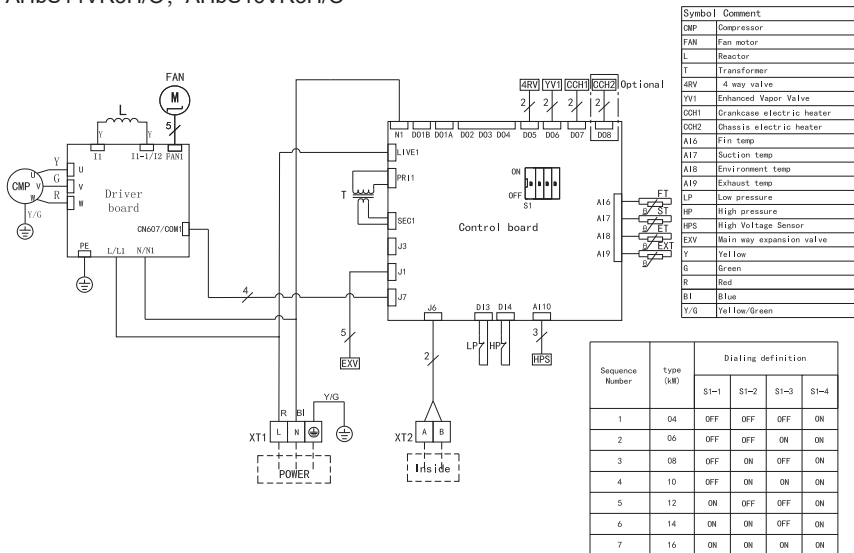

Symbol	Comment
CMP	Compressor
FAN	Fan motor
L	Reactor
T	Transformer
4RV	4 way valve
YV1	Enhanced Vapor Valve
COH1	Crankcase electric heater
COH2	Chassis electric heater
AI6	Fin temp
AI7	Suction temp
AI8	Environment temp
AI9	Exhaust temp
LP	Low pressure
HP	High pressure
HPS	High Voltage Sensor
EXV	Main way expansion valve
Y	Yellow
G	Green
R	Red
Bl	Blue
Y/G	Yellow/Green

Sequence Number	type (aB)	Dialing definition			
		S1-1	S1-2	S1-3	S1-4
1	04	OFF	OFF	OFF	ON
2	06	OFF	OFF	ON	ON
3	08	OFF	ON	OFF	ON
4	10	OFF	ON	ON	ON
5	12	ON	OFF	OFF	ON
6	14	ON	ON	OFF	ON
7	16	ON	ON	ON	ON

### AHbS12VR3X/O, AHbS14VR3X/O, AHbS16VR3X/O

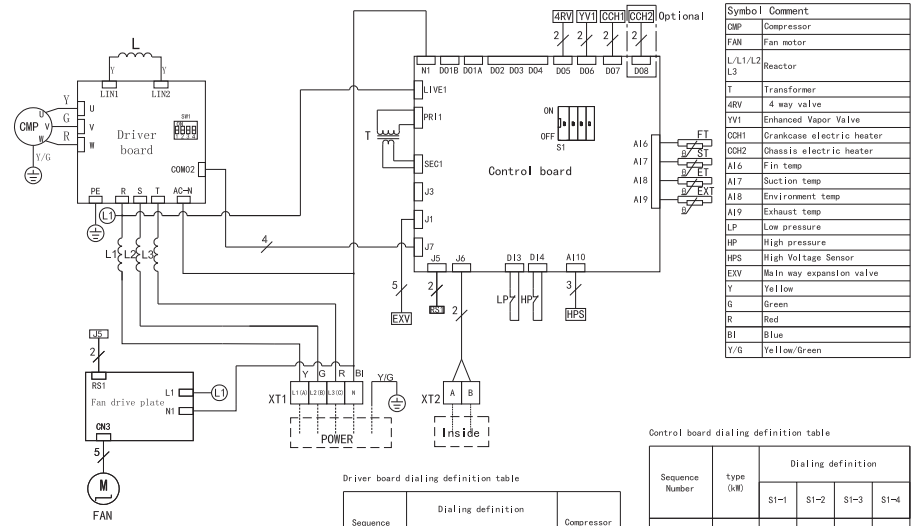

Symbol	Comment
CMP	Compressor
FAN	Fan motor
L/L1/L2/L3	Reactor
T	Transformer
4RV	4 way valve
YV1	Enhanced Vapor Valve
COH1	Crankcase electric heater
COH2	Chassis electric heater
AI6	Fin temp
AI7	Suction temp
AI8	Environment temp
AI9	Exhaust temp
LP	Low pressure
HP	High pressure
HPS	High Voltage Sensor
EXV	Main way expansion valve
Y	Yellow
G	Green
R	Red
Bl	Blue
Y/G	Yellow/Green

Control board dialing definition table

Sequence Number	type (aB)	Dialing definition			
		S1-1	S1-2	S1-3	S1-4
5	12	ON	OFF	OFF	ON
6	14	ON	ON	OFF	ON
7	16	ON	ON	ON	ON

Driver board dialing definition table

Sequence number	Dialing definition				Compressor model
	SW1-1	SW1-2	SW1-3	SW1-4	
1	ON	OFF	OFF	OFF	9KD420ZA21

The wiring diagram is only for reference, designs and specifications might be changed without prior notice.

### 3.10 Indoor Unit Code Dialing

According to whether the following system is used for dialing when the system is installed: hot water system, solar energy, boiler, etc., see the table below.

No.	Dialing Code	SW2-1	SW2-2	SW2-3	SW2-4	SW2-5	SW2-6
		Hot Water	Solar	Boiler Hot Water	Boiler Heating	Heating and Hot Water	Electric Heat for DHW
1	ON	Valid	Valid	Valid	Valid	Valid	Valid
2	OFF	Invalid	Invalid	Invalid	Invalid	Invalid	Invalid
PCB Default Value		OFF	OFF	OFF	OFF	OFF	OFF

# Controller Operation Instruction

## 4.1 Initial Interface

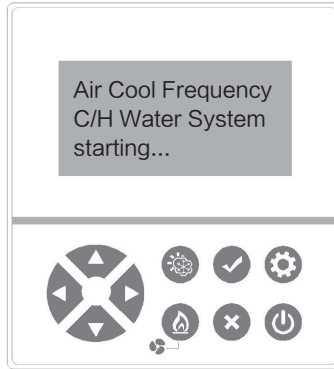

The system goes on the initial interface and displays the system category; Wait about 8 seconds to enter the main interface.

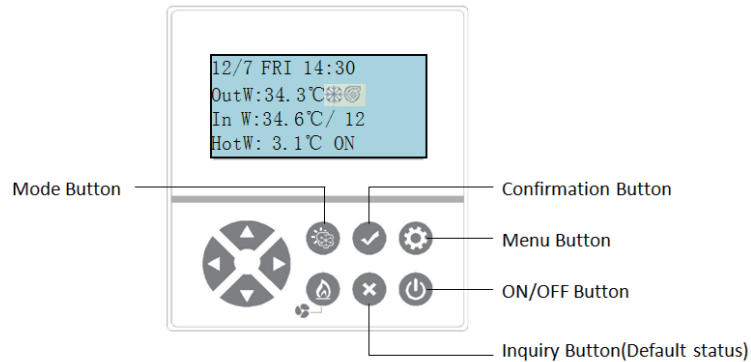

Main interface display content meaning is as follows:

First line: present date, week, and time information;

Second line: Outlet water temperature and Setting mode, water pump status;







Third line: Return water temperature, and setting temperature;

Forth line: Ambient temperature or hot water temperature (Sanitary hot water function valid) , On/Off status.

## Function button instruction :

- ▲, ▼ are used for page up/down, ◀, ▶ are used for parameter adjustment.

- Mode button «  »

- \* Shortly press “  ” to set unit working mode. When set mode background become black, shortly press “  ” to switch set mode, cooling  , heating  , Hot water  cooling+ hot water  , heating + hot water 



- Confirmation button «  »

- \* Shortly press “  ” to make confirmation.



- Menu button «  »

- \* In main interface, shortly press menu button “  ” to enter menu interface; press main menu button to return to upper menu, if no upper manu then return to Main interface.

- On/Off button «  »

- \* Under unit on condition, long press“  ”with 3s to switch off the unit, Under unit off condition, long press “  ” with 3s to switch on the unit.

- Inquiry button «  »

- \* Shortly press“  ” to enter real-time fault inquiry interface, under fault inquiry interface, press “  ” button to return to main interface.

- «  » is universal design, the button is invalid.

## Operation Instruction

### Switch on the unit

1. Press “

### Other operation instruction

- For manual defrost, manual Electric heater, auto sterilization, solar hot water etc function set, please refer 4.2.4.
- Time and date, holiday function, weekly function set, please refer 4.2.7.
- When remote switch off, unit anti-freezing, unit defrosting, sterilization or unit failure, line 4 will display corresponding prompts, multiple states will display for 3 seconds in turn.
- When unit off or standby or malfunction shutdown, if unit meet defrost condition, then main interface water pump “

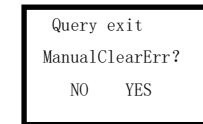

When multiple malfunction records, press “▲” “▼” to automatically enter previous page or next page, No.xxx is current alarm serial no, current: aaa is total alarm qty, all alarms can be inquired; press “

## 4.2 User interface

### 4.2.1 Main menu

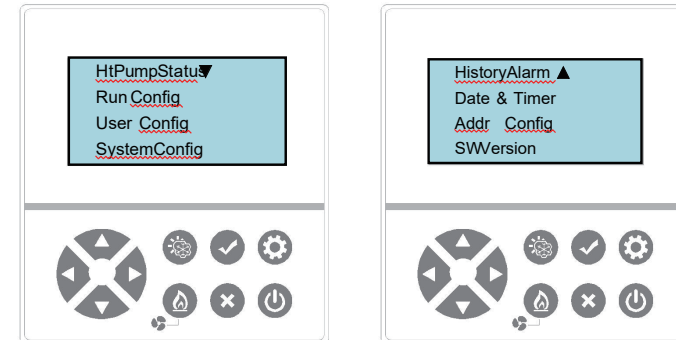

When displaying the main interface, press the menu button “

### 4.2.2 HtPumpStatus

For querying the operation status of the unit and understanding the operation parameters of the unit, it needs to be operated by professionals. Misoperation will lead to abnormal operation of the unit, and even to failure or damage of the unit.

### 4.2.3 Run Config

For setting the current operating parameters of the unit, it needs to be operated by professionals. Misoperation will lead to abnormal operation of the unit, and even to failure or damage of the unit.

### 4.2.4 User Config

[User Config]  
Mode&TempSet  
Manual Defrost  
Manual EH ▼

For special function settings, specifically: Mode&Temp Set、Manual Defrost、Manual EH、Ster setting、AutoSter Set、Solar HotW etc. Customers can set up according to their actual requirements.

\* After setting the parameters of each page, press the confirmation button “” to reserve the setup.

#### ■ Mode&Temp Set

Used for unit operation mode and temperature setting. Choice Mode&Temp Set, press the confirmation button “” Enter the graphical settings interface. At this point, you can use the up and down buttons “▲” “▼” Select the parameter items that need to be modified (the selected parameter is in the inverted state); Press the left and right buttons “◀” “▶” to change the parameter data.

\* Cool、Heat、HotW as below:

[Mode&Temp Set]  
Run Mode: Cool  
Set Temp: 12°C

[Mode&Temp Set]  
Run Mode: Heat  
Set Temp: 42°C

[Mode&Temp Set]  
Run Mode: HotW  
Set Temp: 50°C

\* C+W(Cool+Hotw)、H+W(Heat+Hotw) as below:

[Mode&Temp Set]  
Run Mode: C+W  
Set Temp: 12°C  
HotW Set: 50°C

[Mode&Temp Set]  
Run Mode: H+W  
Set Temp: 42°C  
HotW Set: 50°C

#### ■ Manual Defrost

[Manual Defrost]  
Manual Defrost?  
NO YES

Used for manual defrosting of units. When the outdoor machine defrosting is not clean for some reasons, manual defrosting can be used for defrosting.



Select [Manual Defrost], press the confirmation button “”. And enter the setting interface as shown.

Press the left and right button “◀” “▶” Select whether to defrost or not, select and press the confirmation button “” to perform corresponding operation.

\* YES manual defrosting, NO manual defrosting, this function is effective for one time.

#### ■ Manual EH

[Manual EH]  
EH: Auto

Used for manual opening of electric heating. Select Manual EH and press the confirmation button “”, Enter the graphical settings display interface, through the left and right buttons “◀” “▶” Select whether to turn on electric heating or not, select and press the confirmation button “” to perform corresponding operations.

\* OPEN electric heating starts, CLOSE electric heating does not start, this function is effective for one time.

\* Default setting is AUTO, the electric heater would operate according to the ambient temperature, water temperature and so on.

\* Chang this setting to YES, then you can get fast heating. When the water temperature reached to set temperature, the setting would automatically change to AUTO.

#### ■ Ster-Einstellung

[Ster setting ]  
Manu Close  
Auto: OFF  
HT Last 0 mins

Used for sterilization mode selection of domestic hot water tank. Under Setting, press the confirmation button “”, enter the graphical settings display interface. By up and down button “▲” “▼” Select manual sterilization, automatic sterilization switch, high temperature duration parameters, through the left and right buttons “◀” “▶” Adjustment parameters: manual ON or OFF for sterilization, automatic ON or OFF for sterilization, setting of high temperature duration for sterilization.

Before sterilization operation, it is necessary to confirm whether there is electric heater for DHW in the domestic hot water tank. If there is no auxiliary electric heating, this function should not be carried out. Otherwise, the unit mode will be forced to maintain: refrigeration + hot water (summer) or heating + hot water (winter), and the hot water temperature will remain at a very high temperature, and energy consumption will increase.

The water temperature would be very high after sterilization function, if you use the hot water without mixing enough cold water, it would cause severe burns. So an automatic water mixing valve is strongly recommended to ensure a safe water temperature.

\* Manu: Open, the unit immediately operates sterilization mode, according to the default or set parameters of domestic hot water tank sterilization operation. After sterilization, it will automatically change to Manu: Close.

\* When Auto:ON, the unit is in the mode of automatic sterilization, which can run automatically after meeting the conditions set under the "AutoSter Set".

\* HT Last 0 mins: For the retention time after the temperature of domestic hot water reaches the sterilization temperature. The longer it takes, the more thoroughly the bacteria are killed. But not as long as possible, because too long will lead to increased energy consumption.



■ AutoSter Set

**[AutoSter Set]**  
Opentime 12:00  
period : 7 day  
Temp 65 °C

Used for adjusting parameters of automatic sterilization of domestic hot water tank. Select [AutoSter Set] and press the confirmation button "✓", Enter the graphical settings display interface, through the up and down buttons "▲" "▼" Select the parameters that need to be modified: including Opentime (sterilization start time), period, Temp. By right and left buttons "◀" "▶" to change the parameter data.

In order to be effective, the "AUTO" must be set to ON under Ster setting. Factory default is OFF.

\* Sterilization temperature and Minimum exposure period:

Ster TEMP (°C)	Minimum exposure period
70°C or greater	1s
66°C	2min
60°C	32min
55°C	6h

■ Solar HotW

**[Solar HotW]**  
FreeHeat Close  
FreeHeatTemp  
70°C

Used for solar energy hot water parameters setting. This function is valid when the system must be installed in the unit solar panels and used to heat the sanitary hot water tank.

Select Solar HotW, and press the confirmation button "✓", Enter the solar energy hot water display interface, through the up and down buttons "▲" "▼" Select the parameters that need to be modified: including FreeHeat and FreeHeat Temp. By right and left buttons "◀" "▶" to change the parameter data.

\*FreeHeat: ON, When the sanitary hot water reaches the setting temperature by the line controller, the unit no longer runs heating mode to heat sanitary hot water tank, but solar energy will heat sanitary hot water tank until the hot water temperature  $\geq$ FreeHeatTemp.

\*FreeHeatTemp setting higher than sanitary hot water temperature setting by the line controller.

■ Auto Temp Ctrl

**[AutoTemp Ctrl]**  
Auto Enable  
Temp Curve  
Heat Thj&Ts

When unit is in cooling and heating modes, the return water temperature is automatically controlled. When 'Auto Enable' is ON, select the control curve through 'Temp Curve', then the actual return water temperature will be automatically adjusted according to the return water temperature. There are 2 types of control curves for

cooling, and 12 types for heating. If the user is not satisfied with the existing control curves, he can also customize the heating temperature curve through 'Heat Thj&Ts', and the cooling temperature curve through 'Cool Thj&Ts'. When 'Auto Enable' is OFF, the actual return water temperature is controlled according to the user's set value.

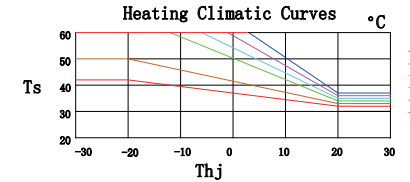
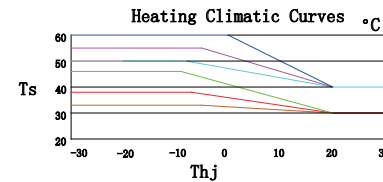
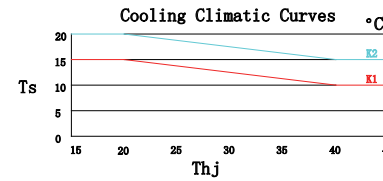

When 'Auto Enable' is ON, 'In W' on the main one control, in which two wires will automatically change to 'Auto'.

When the user manually sets the return water temperature, 'Auto Enable' will automatically change to 'OFF', and 'In W' on the main one control, in which two wires will change to the temperature set by the user.

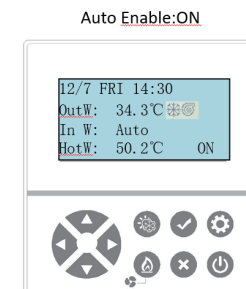
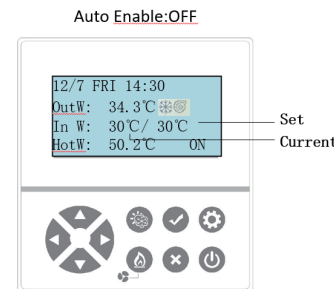

■ 2nd Temp Set

**[ 2nd Temp Set ]**  
Enable:ON

In the heating mode, when the 2nd temperature zone setting 'Enable' is ON, the main one control, in which two wires is shown in the figure below. Now you can set the heating return water temperature and the temperature of the 2nd temperature zone. After the setting is completed in 5 seconds, the main one control, in which two wires will display the actual outlet water temperature.

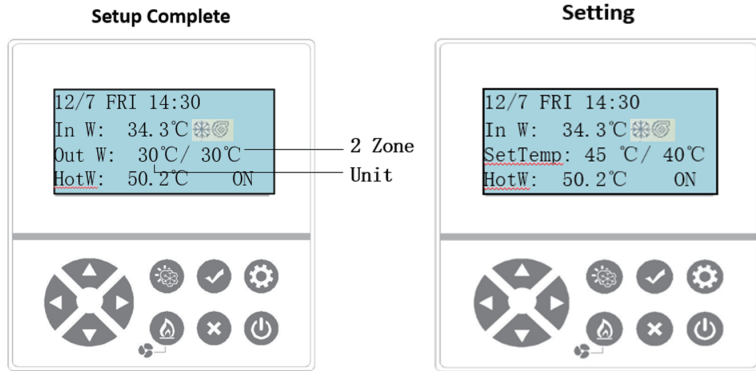

When the heating temperature is set to 'Auto', the main one control, in which two wires is:

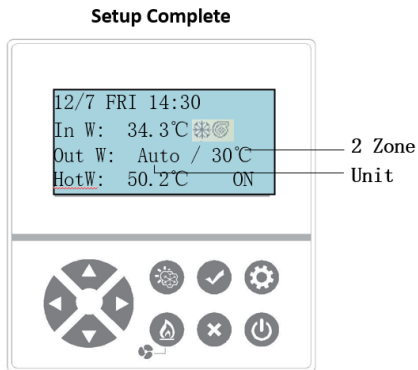

4.2.5 SystemConfig

Setting unit parameters, which requires professional operation, do not operate on your own, otherwise it will lead to abnormal operation of the unit.

4.2.6 HistoryAlarm

NO.xxx Hist:aaa  
Num module  
1#Comp HP Err  
120610 10:30:33

History Alarm Record Inquiry. Select HistoryAlarm in the function menu, Press confirmation button "✓" to enter the interface, as left side shown. If there is no default, display "no alarm records".

No.xxx is present alarm serial number, History: aaa is total alarm times. The maximum can record 255 historical records, and the fourth lines show the time of the alarm. The time format is year, month, day hour: minute: second.

When there are several default records, use button "▲" "▼" to select upper page or next page. Press menu button "⚙" to return to upper menu.

4.2.7 Date&Timer

**【Date & Timer】**  
DateTime  
WeekTime  
HoliTime

Present Date and time、weekly timer、Holiday Timer setup  
Select **【Date and Timer】** in function menu, press confirmation button "✓" to enter the interface as shown on the left.

■ DateTime

**【DateTime】**  
DATE 12/ 02/ 10  
WEEKThu  
TIME 10:20:00

Present Date and time modification. Select **【DateTime】** in function menu, Press confirmation button "✓" to enter the interface as shown on the left.

Press "▲" "▼" button to move cursor to choose date and time, Press "◀" "▶" to increase and decrease the data;

After all Settings are completed, and press confirmation button "✓" to valid the setup and return to upper menu, and press menu button "⚙" to return to upper menu, and the setting is invalid.

### ■ WeekTime

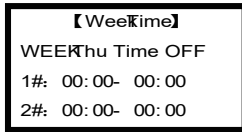

Used for weekly timing setting. Select WeekTime and press the confirmation button “” Enter the interface, as shown on the left.

Every day of the week has two periods of time, the time before each period is the boot time, and the time after each period is the shutdown time; through the up and down buttons. “” “” Moving cursor to select the parameters of week, timing ON or OFF, timing time, press left and right button “” “” Modify the parameter values and press the confirmation button when all the settings are completed. “” Make the settings work and return to the superior menu, press the menu button “” Then return to the superior menu, the setting is invalid. If the timing is valid, the timing switch parameter should be set to ON.

### ■ HoliTime

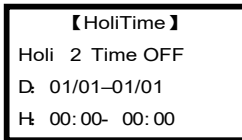

Used for holiday setting. Select HoliTime and press the confirmation button “” Enter the interface, as shown on the left.

The first line of meaning: Holi serial number and validity (OFF/ON); The second line means: start and end of the holiday;

The third line means: daily boot time and shutdown time during holidays.

There are 5 holidays available in this module. Specifically through the up and down buttons “” “” Move the cursor to select the vacation serial number, timing ON or OFF, the start and end dates of the vacation timing, the start and shutdown time parameters of the timing, press the left and right buttons. “” “” Modify the parameter values and press the confirmation button when all the settings are completed “” Make the settings work and return to the superior menu, press the menu button “” Then return to the superior menu, the setting is invalid. If the timing is valid, the timing switch parameter should be set to ON.

If the ambient temperature would lower than 0℃ during vacation, we suggest you to set the machine mode to “H+W”, with the temperature of heating and hot water temperature as 30℃, and set the working time of machine no less than 30 minutes before vacation. After vacation, you can change the set temperature to make the machine quickly work quickly to reach your requirement.

If the ambient temperature would lower than 0℃ during vacation, do not power off the machine or set the machine to other mode except “H+W”. Otherwise, water pipe would froze and break due to the low temperature.

## 5.1 Backup Heat Source (Boiler) Management

The backup heat source (boiler) can be connected to the domestic hot water system and heating system. It is switched between these two systems by an external electric three-way valve. The heat pump would automatically control the start and stop of the backup heat source and the switching of the three-way valve.

When the backup heat source (boiler) is connected to the heat pump system, you can set the water piping system to achieve target functions. The settings information is in chapter “3.9 Indoor Machine Dialing Code”.

Operation of the backup heat source (boiler) is automatically operated by the PCB board according to the demand.

## 5.2 Solar Management (Optional)

- User could choose whether to use solar auxiliary hot water. When the solar energy is effective, the solar water temperature sensor and inlet water temperature sensor on the hot water control board is effective, otherwise the solar water outlet temperature sensor and inlet water temperature sensor is invalid and the controller doesn't detect them.
- When the backup heat source solar boiler is connected to the heat pump system, you can set the water piping system to achieve target functions. The settings information is in chapter “3.9 Indoor Machine Dialing Code”.
- Solar heating is divided into on-demand heating and self-heating.
- On-demand heating depends on the set temperature of hot water in the wired controller. When the hot water temperature in the water tank is no less than the set temperature of hot water, solar heating is stopped.
- Self-heating is determined by the heating water temperature in the parameter table. When the hot water temperature is no less than the heating water temperature in the water tank, solar heating is stopped.
- Factory default setting is self-heating.
- When the heat pump is timing off or malfunction happens, solar boiler would keep on providing heating to the heat pump system.

## 5.3 Auxiliary Electric Heater (Optional)

The user determines whether additional auxiliary electric heating is added to the outlet pipeline (for terminal heating) according to the actual needs. The additional auxiliary electric heating is connected to the main power supply through the AC contactor, and the control port of the AC contactor is parallel to the auxiliary electric heating control port on the indoor computer, which is controlled by the host computer.

## Commissioning

### Before start up

- 1) Check the piping connection
- 2) Check the electrical connections
- 3) Install the domestic hot water system

### Startup

- 1) Start the main power switch
- 2) Set the pump parameters
- 3) Select the operating mode
- 4) Start up the heat pump

### NOTE!

- Check the operation of the indoor and outdoor units. The unit check is very important. After the installation is complete, make sure everything is normal before commissioning;
- Check the temperature difference between supply and return temperatures, make sure it is consistent with previously described. Low temperature difference or high temperature difference may cause malfunction of the heat pump or energy waste;
- Do not set the heating temperature too high;
- Do not set the hot water temperature too high;
- After commissioning fill in installation record sheet.

## Specifications

### 7.1 Nomenclature

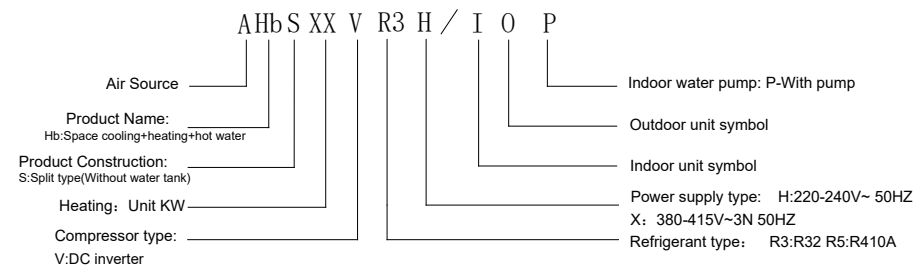

### 7.2 Technical parameters

#### Remark:

##### 1. Testing Condition:

- Heating\*1: Ambient Temp.(DB/WB):7 C/6 C , Water Temp.(In/Out):30 C/35 C .
- Heating\*2: Ambient Temp.(DB/WB):7 C/6 C , Water Temp.(In/Out):40 C/45 C .
- Heating\*3: Ambient Temp.(DB/WB):7 C/6 C , Water Temp.(In/Out):47 C/55 C .
- Cooling\*4: Ambient Temp.(DB/WB):35 C/24 C , Water Temp.(In/Out):23 C/18 C .
- Cooling\*5: Ambient Temp.(DB/WB):35 C/24 C , Water Temp.(In/Out):12 C/7 C .

2. The above data test reference EN14511:2011.

3. The data above is only for reference, designs and specifications might be changed without prior notice.

Outdoor unit			AHbS4VR3H/O	AHbS6VR3H/O	AHbS8VR3H/O	AHbS10VR3H/O
Indoor unit			AHbS6VR3H/IP		AHbS10VR3H/IP	
Power supply		V/Ph/Hz	220~240/1/50	220~240/1/50	220~240/1/50	220~240/1/50
Heating*1	Capacity	kW	4.2	6.2	8.0	10.0
	Power input	kW	0.82	1.28	1.63	2.02
	COP	kW/kW	5.10	4.95	4.91	4.95
Heating*2	Capacity	kW	4.3	6.3	8.1	10.0
	Power input	kW	1.13	1.70	2.10	2.67
	EER	kW/kW	3.80	3.70	3.85	3.75
Heating*3	Capacity	kW	4.4	6.0	7.5	9.5
	Power input	kW	1.49	2.03	2.36	3.06
	COP	kW/kW	2.95	2.95	3.18	3.10
Cooling*4	Capacity	kW	4.5	6.5	8.4	10.0
	Power input	kW	0.81	1.34	1.66	2.08
	EER	kW/kW	5.56	4.85	5.06	4.81
Cooling*5	Capacity	kW	4.7	7.0	7.5	8.2
	Power input	kW	1.36	2.33	2.22	2.52
	EER	kW/kW	3.45	3.00	3.35	3.25
Seasonal space heating energy efficiency class	water outlet @ 35°C		A+++	A+++	A+++	A+++
	water outlet @ 55°C		A++	A++	A++	A++
Sound power level	Db		56	58	59	60
Dimension (W×H×D)	mm		1045×405×770	1045×405×770	995×390×1015	995×390×1015
Packing (W×H×D)	mm		1170×520×895	1170×520×895	1145×510×1160	1145×510×1160
Net/gross weight	kg		62/68	62/68	78/88	78/88
Liquid pipe	Type		Flaring	Flaring	Flaring	Flaring
	Dia.(OD)	mm	Φ6.35	Φ6.35	Φ6.35	Φ6.35
Gas pipe	Type		Flaring	Flaring	Flaring	Flaring
	Dia.(OD)	mm	Φ12.7	Φ12.7	Φ15.88	Φ15.88
Max. piping length	m		20	20	20	30
Refrigerant	Type		R32	R32	R32	R32
	Quantity	kg	1.05	1.05	1.45	1.45
Ambient temperature range	Cooling	°C	-5~43°C	-5~43°C	-5~43°C	-5~43°C
	Heating	°C	-25~43°C	-25~43°C	-25~43°C	-25~43°C
	DHW	°C	-25~43°C	-25~43°C	-25~43°C	-25~43°C
Water temperature range	Cooling	°C	5~25°C	5~25°C	5~25°C	5~25°C
	Heating	°C	25~60°C	25~60°C	25~60°C	25~60°C
	DHW	°C	30~60°C	30~60°C	30~60°C	30~60°C

Outdoor unit			AHbS12VR3H/O	AHbS14VR3H/O	AHbS16VR3H/O
Indoor unit			AHbS16VR3H/IP		
Power supply		V/Ph/Hz	220~240/1/50	220~240/1/50	220~240/1/50
Heating*1	Capacity	kW	12.1	14.5	15.9
	Power input	kW	2.44	3.15	3.53
	COP	kW/kW	4.95	4.60	4.50
Heating*2	Capacity	kW	12.3	14.1	16.0
	Power input	kW	3.32	3.92	4.57
	EER	kW/kW	3.70	3.60	3.50
Heating*3	Capacity	kW	11.9	13.8	16.0
	Power input	kW	3.90	4.68	5.61
	COP	kW/kW	3.05	2.95	2.85
Cooling*4	Capacity	kW	12.0	13.5	14.9
	Power input	kW	2.69	3.21	3.72
	EER	kW/kW	4.45	4.20	4.00
Cooling*5	Capacity	kW	11.5	12.4	14.0
	Power input	kW	3.83	4.20	4.91
	EER	kW/kW	3.00	2.95	2.85
Seasonal space heating energy efficiency class	water outlet @ 35°C		A+++	A+++	A+++
	water outlet @ 55°C		A++	A++	A++
Sound power level	Db		64	65	68
Dimension (W×H×D)	mm		995×390×1015	995×390×1015	995×390×1015
Packing (W×H×D)	mm		1145×510×1160	1145×510×1160	1145×510×1160
Net/gross weight	kg		95/105	95/105	95/105
Liquid pipe	Type		Flaring	Flaring	Flaring
	Dia.(OD)	mm	Φ9.52	Φ9.52	Φ9.52
Gas pipe	Type		Flaring	Flaring	Flaring
	Dia.(OD)	mm	Φ15.88	Φ15.88	Φ15.88
Max. piping length	m		30	30	30
Refrigerant	Type		R32	R32	R32
	Quantity	kg	1.84	1.84	1.84
Ambient temperature range	Cooling	°C	-5~43°C	-5~43°C	-5~43°C
	Heating	°C	-25~43°C	-25~43°C	-25~43°C
	DHW	°C	-25~43°C	-25~43°C	-25~43°C
Water temperature range	Cooling	°C	5~25°C	5~25°C	5~25°C
	Heating	°C	25~60°C	25~60°C	25~60°C
	DHW	°C	30~60°C	30~60°C	30~60°C

Outdoor unit		AHbS12VR3X/O	AHbS14VR3X/O	AHbS16VR3X/O	
Indoor unit		AHbS16VR3X/IP			
Power supply		V/Ph/Hz	380~415/3/50	380~415/3/50	380~415/3/50
Heating*1	Capacity	kW	12.1	14.5	15.9
	Power input	kW	2.44	3.15	3.53
	COP	kW/kW	4.95	4.60	4.50
Heating*2	Capacity	kW	12.3	14.1	16.0
	Power input	kW	3.32	3.92	4.57
	EER	kW/kW	3.70	3.60	3.50
Heating*3	Capacity	kW	11.9	13.8	16.0
	Power input	kW	3.90	4.68	5.61
	COP	kW/kW	3.05	2.95	2.85
Cooling*4	Capacity	kW	12.0	13.5	14.9
	Power input	kW	2.69	3.21	3.72
	EER	kW/kW	4.45	4.20	4.00
Cooling*5	Capacity	kW	11.5	12.4	14.0
	Power input	kW	3.83	4.20	4.91
	EER	kW/kW	3.00	2.95	2.85
Seasonal space heating energy efficiency class	water outlet @ 35°C		A+++	A+++	A+++
	water outlet @ 55°C		A++	A++	A++
Sound power level		Db	65	65	68
Dimension (W×H×D)		mm	995×390×1015	995×390×1015	995×390×1015
Packing (W×H×D)		mm	1145×510×1160	1145×510×1160	1145×510×1160
Net/gross weight		kg	105/116	105/116	105/116
Liquid pipe	Type		Flaring	Flaring	Flaring
	Dia.(OD)	mm	Φ9.52	Φ9.52	Φ9.52
Gas pipe	Type		Flaring	Flaring	Flaring
	Dia.(OD)	mm	Φ15.88	Φ15.88	Φ15.88
Max. piping length		m	30	30	30
Refrigerant	Type		R32	R32	R32
	Quantity	kg	1.84	1.84	1.84
Ambient temperature range	Cooling	°C	-5~43°C	-5~43°C	-5~43°C
	Heating	°C	-25~43°C	-25~43°C	-25~43°C
	DHW	°C	-25~43°C	-25~43°C	-25~43°C
Water temperature range	Cooling	°C	5~25°C	5~25°C	5~25°C
	Heating	°C	25~60°C	25~60°C	25~60°C
	DHW	°C	30~60°C	30~60°C	30~60°C

Indoor unit			AHbS6VR3H/IP	AHbS10VR3H/IP	AHbS16VR3H/IP	AHbS16VR3X/IP
Power supply		V/Ph/Hz	220~240/1/50	220~240/1/50	220~240/1/50	380~415/3/50
Sound power level		dB	40	42	43	43
Dimension (W×H×D)		mm	470×790×270	470×790×270	470×790×270	470×790×270
Packing (W×H×D)		mm	550×950×340	550×950×340	550×950×340	550×950×340
Net/gross weight		kg	41/46	42/47	43/48	45/51
Piping connection	Outlet	mm	G1-1/4"	G1-1/4"	G1-1/4"	G1-1/4"
	Inlet	mm	G1-1/4"	G1-1/4"	G1-1/4"	G1-1/4"
Safety valve		kPa	600	600	600	600
Drainage pipe Dia.		mm	R3/4"	R3/4"	R3/4"	R3/4"
Expansion tank	Volume	L	8	8	8	8
	Charge pressure	kPa	300	300	300	300
Water side heat exchanger	Type		Plate type	Plate type	Plate type	Plate type
Water pump	Pump head	m	9	9	9	9
Refrigerant circuit	Liquid side Dia.	mm	Φ6.35	Φ6.35	Φ9.52	Φ9.52
	Gas side Dia.	mm	Φ12.7	Φ15.88	Φ15.88	Φ15.88
Backup E-heater	Power supply	V/Ph/Hz	220~240/1/50	220~240/1/50	220~240/1/50	380~415/3/50
	Capacity	kW	3	3	3	9
Room temperature range		°C	5 ~ 35	5 ~ 35	5 ~ 35	5 ~ 35
Water inlet temperature range	Cooling	°C	10~30	10~30	10~30	10~30
	Heating	°C	20~55	20~55	20~55	20~55
	DHW	°C	25~50	25~50	25~50	25~50
Water outlet temperature range	Cooling	°C	5~25	5~25	5~25	5~25
	Heating	°C	25~65	25~65	25~65	25~65
	DHW	°C	30~60	30~60	30~60	30~60

The data above is only for reference, designs and specifications might be changed without prior notice.

## Maintenance and fault

---

- 1) Regular cleaning finned air heat exchanger. It can be washed or steam cleaned.
- 2) Check the water conditions. Loosen the exhaust cock, or drain through the drain cock, if the water quality decreases, replace the contaminated water.
- 3) Regular cleaning the contaminated fan blades.
- 4) Check the abnormal sound. Please check where abnormal sound occurs and investigate the cause, when the reason is unclear, please contact the manufacturer or supplier.
- 5) Check whether there is air inside the water pipe system. Even taking exhaust operation, sometimes the air still can enter the system, so every once in a while it should to exhaust air.
- 6) The unit uses special refrigeration oil, not mixed with other oils. Refrigeration oil used in this unit: POE.VG74
- 7) The refrigerant used in this unit is R32.

### Checks to the area

Prior to beginning work on systems containing flammable refrigerants, safety checks are necessary to ensure that the risk of ignition is minimised. For repair to the refrigerating system, the following precautions shall be complied with prior to conducting work on the system.

### Work procedure

Work shall be undertaken under a controlled procedure so as to minimise the risk of a flammable gas or vapour being present while the work is being performed.

### General work area

All maintenance staff and others working in the local area shall be instructed on the nature of work being carried out. Work in confined spaces shall be avoided. The area around the workspace shall be sectioned off. Ensure that the conditions within the area have been made safe by control of flammable material.

### Checking for presence of refrigerant

The area shall be checked with an appropriate refrigerant detector prior to and during work, to ensure the technician is aware of potentially flammable atmospheres. Ensure that the leak detection equipment being used is suitable for use with flammable refrigerants, i.e. nonsparking, adequately sealed or intrinsically safe.

### Presence of fire extinguisher

If any hot work is to be conducted on the refrigeration equipment or any associated parts, appropriate fire extinguishing equipment shall be available to hand. Have a dry powder or CO2 fire extinguisher adjacent to the charging area.

### No ignition sources

No person carrying out work in relation to a refrigeration system which involves exposing any pipe work that contains or has contained flammable refrigerant shall use any sources of ignition in such a manner that it may lead to the risk of fire or explosion. All possible ignition sources, including cigarette smoking, should be kept sufficiently far away from the site of installation, repairing, removing and disposal, during which flammable refrigerant can possibly be released to the surrounding space. Prior to work taking place, the area around the equipment is to be surveyed to make sure that there are no flammable hazards or ignition risks. "No Smoking" signs shall be displayed.

### Ventilated area

Ensure that the area is in the open or that it is adequately ventilated before breaking into the system or conducting any hot work. A degree of ventilation shall continue during the period that the work is carried out. The ventilation should safely disperse any released refrigerant and preferably expel it externally into the atmosphere.

### Checks to the refrigeration equipment

Where electrical components are being changed, they shall be fit for the purpose and to the correct specification. At all times the manufacturer's maintenance and service guidelines shall be followed. If in doubt consult the manufacturer's technical department for assistance. The following checks shall be applied to installations using flammable refrigerants:

- the charge size is in accordance with the room size within which the refrigerant containing parts are installed;
- the ventilation machinery and outlets are operating adequately and are not obstructed;
- if an indirect refrigerating circuit is being used, the secondary circuit shall be checked for the presence of refrigerant;
- marking to the equipment continues to be visible and legible. Markings and signs that are illegible shall be corrected;
- refrigeration pipe or components are installed in a position where they are unlikely to be exposed to any substance which may corrode refrigerant containing components, unless the components are constructed of materials which are inherently resistant to being corroded or are suitably protected against being so corroded.



## Checks to electrical devices

Repair and maintenance to electrical components shall include initial safety checks and component inspection procedures. If a fault exists that could compromise safety, then no electrical supply shall be connected to the circuit until it is satisfactorily dealt with. If the fault cannot be corrected immediately but it is necessary to continue operation, an adequate temporary solution shall be used. This shall be reported to the owner of the equipment so all parties are advised.

Initial safety checks shall include:

- that capacitors are discharged: this shall be done in a safe manner to avoid possibility of sparking;
- that no live electrical components and wiring are exposed while charging, recovering or purging the system
- that there is continuity of earth bonding.

## Repairs to sealed components

### Attention!

- During repairs to sealed components, all electrical supplies shall be disconnected from the equipment being worked upon prior to any removal of sealed covers, etc. If it is absolutely necessary to have an electrical supply to equipment during servicing, then a permanently operating form of leak detection shall be located at the most critical point to warn of a potentially hazardous situation.
- Particular attention shall be paid to the following to ensure that by working on electrical components, the casing is not altered in such a way that the level of protection is affected. This shall include damage to cables, excessive number of connections, terminals not made to original specification, damage to seals, incorrect fitting of glands, etc.

Ensure that apparatus is mounted securely.

Ensure that seals or sealing materials have not degraded such that they no longer serve the purpose of preventing the ingress of flammable atmospheres. Replacement parts shall be in NOTE The use of silicon sealant may inhibit the effectiveness of some types of leak detection equipment. Intrinsically safe components do not have to be isolated prior to working on them.

## Repair to intrinsically safe components

Do not apply any permanent inductive or capacitance loads to the circuit without ensuring that this will not exceed the permissible voltage and current permitted for the equipment in use.

Intrinsically safe components are the only types that can be worked on while live in the presence of a flammable atmosphere. The test apparatus shall be at the correct rating.

Replace components only with parts specified by the manufacturer. Other parts may result in the ignition of refrigerant in the atmosphere from a leak.

## Cabling

Check that cabling will not be subject to wear, corrosion, excessive pressure, vibration, sharp edges or any other adverse environmental effects. The check shall also take into account the effects of ageing or continual vibration from sources such as compressors or fans.

## Detection of flammable refrigerants

Under no circumstances shall potential sources of ignition be used in the searching for or detection of refrigerant leaks. A halide torch (or any other detector using a naked flame) shall not be used.

## Leak detection methods

The following leak detection methods are deemed acceptable for systems containing flammable refrigerants.

Electronic leak detectors shall be used to detect flammable refrigerants, but the sensitivity may not be adequate, or may need re-calibration. (Detection equipment shall be calibrated in a refrigerant-free area.) Ensure that the detector is not a potential source of ignition and is suitable for the refrigerant used. Leak detection equipment shall be set at a percentage of the LFL of the refrigerant and shall be calibrated to the refrigerant employed and the appropriate percentage of gas (25 % maximum) is confirmed.

Leak detection fluids are suitable for use with most refrigerants but the use of detergents containing chlorine shall be avoided as the chlorine may react with the refrigerant and corrode the copper pipe-work.

If a leak is suspected, all naked flames shall be removed/extinguished.

If a leakage of refrigerant is found which requires brazing, all of the refrigerant shall be recovered from the system, or isolated (by means of shut off valves) in a part of the system remote from the leak. Oxygen free nitrogen (OFN) shall then be purged through the system both before and during the brazing process.

## Removal and evacuation

When breaking into the refrigerant circuit to make repairs – or for any other purpose – conventional procedures shall be used. However, it is important that best practice is followed since flammability is a consideration. The following procedure shall be adhered to:

- remove refrigerant;
- purge the circuit with inert gas;
- evacuate;
- purge again with inert gas;
- open the circuit by cutting or brazing.

The refrigerant charge shall be recovered into the correct recovery cylinders. The system shall be “flushed” with OFN to render the unit safe. This process may need to be repeated several times. Compressed air or oxygen shall not be used for this task.

Flushing shall be achieved by breaking the vacuum in the system with OFN and continuing to fill until the working pressure is achieved, then venting to atmosphere, and finally pulling down to a vacuum. This process shall be repeated until no refrigerant is within the system. When the final OFN charge is used, the system shall be vented down to atmospheric pressure to enable work to take place. This operation is absolutely vital if brazing operations on the pipework are to take place.

Ensure that the outlet for the vacuum pump is not close to any ignition sources and there is ventilation available.

## Charging procedures

In addition to conventional charging procedures, the following requirements shall be followed.

- Ensure that contamination of different refrigerants does not occur when using charging equipment. Hoses or lines shall be as short as possible to minimise the amount of refrigerant contained in them.
- Cylinders shall be kept upright.
- Ensure that the refrigeration system is earthed prior to charging the system with refrigerant.
- Label the system when charging is complete (if not already).
- Extreme care shall be taken not to overfill the refrigeration system.

Prior to recharging the system it shall be pressure tested with OFN. The system shall be leak tested on completion of charging but prior to commissioning. A follow up leak test shall be carried out prior to leaving the site.

## Decommissioning

Before carrying out this procedure, it is essential that the technician is completely familiar with the equipment and all its detail. It is recommended good practice that all refrigerants are recovered safely. Prior to the task being carried out, an oil and refrigerant sample shall be taken in case analysis is required prior to re-use of reclaimed refrigerant. It is essential that electrical power is available before the task is commenced.

- a) Become familiar with the equipment and its operation.
- b) Isolate system electrically.
- c) Before attempting the procedure ensure that:
  - mechanical handling equipment is available, if required, for handling refrigerant cylinders;
  - all personal protective equipment is available and being used correctly;
  - the recovery process is supervised at all times by a competent person;
  - recovery equipment and cylinders conform to the appropriate standards.
- d) Pump down refrigerant system, if possible.
- e) If a vacuum is not possible, make a manifold so that refrigerant can be removed from various parts of the system.
- f) Make sure that cylinder is situated on the scales before recovery takes place.

- g) Start the recovery machine and operate in accordance with manufacturer's instructions.
- h) Do not overfill cylinders. (No more than 80 % volume liquid charge).
- i) Do not exceed the maximum working pressure of the cylinder, even temporarily.
- j) When the cylinders have been filled correctly and the process completed, make sure that the cylinders and the equipment are removed from site promptly and all isolation valves on the equipment are closed off.
- k) Recovered refrigerant shall not be charged into another refrigeration system unless it has been cleaned and checked.

## Labelling

Equipment shall be labelled stating that it has been de-commissioned and emptied of refrigerant. The label shall be dated and signed. Ensure that there are labels on the equipment stating the equipment contains flammable refrigerant.

## Recovery

When removing refrigerant from a system, either for servicing or decommissioning, it is recommended good practice that all refrigerants are removed safely.

When transferring refrigerant into cylinders, ensure that only appropriate refrigerant recovery cylinders are employed. Ensure that the correct number of cylinders for holding the total system charge are available. All cylinders to be used are designated for the recovered refrigerant and labelled for that refrigerant (i.e. special cylinders for the recovery of refrigerant). Cylinders shall be complete with pressure relief valve and associated shut-off valves in good working order. Empty recovery cylinders are evacuated and, if possible, cooled before recovery occurs.

The recovery equipment shall be in good working order with a set of instructions concerning the equipment that is at hand and shall be suitable for the recovery of flammable refrigerants. In addition, a set of calibrated weighing scales shall be available and in good working order. Hoses shall be complete with leak-free disconnect couplings and in good condition. Before using the recovery machine, check that it is in satisfactory working order, has been properly maintained and that any associated electrical components are sealed to prevent ignition in the event of a refrigerant release. Consult manufacturer if in doubt.

The recovered refrigerant shall be returned to the refrigerant supplier in the correct recovery cylinder, and the relevant Waste Transfer Note arranged. Do not mix refrigerants in recovery units and especially not in cylinders.

If compressors or compressor oils are to be removed, ensure that they have been evacuated to an acceptable level to make certain that flammable refrigerant does not remain within the lubricant. The evacuation process shall be carried out prior to returning the compressor to the suppliers. Only electric heating to the compressor body shall be employed to accelerate this process. When oil is drained from a system, it shall be carried out safely.

## Malfunction code

When malfunction happens and malfunction code as following list shows on the display, please contact with professional maintains engineers and report it to him.

NO.	Faults	Description
1	In Sensor Err	Leaving Water Sensor Error
2	Out Sensor Err	Leaving Water Sensor Error
3	IndoorSensor Err	IndoorSensor Error
4	OutEnviSensorErr	Ambient Sensor Error
5	Fin Sensor Err	Fin Sensor Error
6	Disc Sensor Err	Exhaust Sensor Error
7	Suct Sensor Err	Sunction Sensor Error
8	LP SensorErr	Low Pressure Sensor Error
9	Evap Sensor Err	Evaporater Sensor Error
10	EconomizerOutErr	Economizer Outlet Sensor Error
11	EconomizerIn Err	Economizer Intlet Sensor Error
12	Flow Switch Err	Flow Switch Error
13	COMP HP Err	High Pressure Sensor Error
14	COMP LP Err	Low Pressure Sensor Error
15	LWT Over-H	Leaving Water OverHeat protection
16	LWT Over-L	Leaving Water OverLow protection
17	LWT&EWT Over-H	Water IN&OUT Large temperature difference protection
18	Disc Over-H	Exhaust temperature OverHeat
19	Fin Tp Over-H	Fins Temperature OverHeat
20	Driver Dropped	Compressor Driver Disconnected
21	HP SensorErr	High Pressure Sensor Error
22	Plate in Antif	Plate heat exchanger Antifreeze in Cooling Mode
23	Input Protect	Protection against external input
24	CisternSensorErr	WaterTank Sensor Error
25	OutMach Dial Err	Outdoor DIP Switch Error
26	ON Evap Tp Low	Start Evaperator Temp OverLow
27	RunEvap Tp Low	Run Evaperator Temp OverLow
28	InMach Comm Err	Indoor Unit Communication Error
29	HOTW Sensor Err	Hot Water Sensor Error
30	HotEX Sensor Err	HeatExchangerSensorError
31	SolarW SensorErr	Solar Water Temperature Sensor Error
32	InMach Dial Err	indoor DIP Switch Error
33	IPM Over-C	IPM Overcurrent

34	COMPDriveFailure	Compressor Drive Error
35	COMP Over-C	Compressor Overcurrent
36	Input Open Phase	Input voltage phase Error
37	IPM Sample-C Err	IPM current sampling Error
38	Stop PCom Over-H	Power Componet overheat shutdown
39	PrechargingFail	Pre-charging Error
40	Dc Bus Over-V	Dc bus overvoltage
41	Dc Bus Under-V	Dc bus undervoltage
42	Ac Input Under-V	Ac input undervoltage
43	Ac Input Over-C	Ac input overcurrent
44	Vac Sample Err	Input voltage sampling Error
45	DSP&PFC Comm Err	Communication betwven DSP and PFC Error
46	Drive Sensor Err	Drive Temperature Sensor Err
47	DSP&COM CommErr	Communication between DSP and Communication PCB Error
48	Comm. & Host Err	Communication with Mail PCB Error
49	COMP Over-C	Compressor overcurrent alarm
50	COMPWeakMagnetic	Compressor weak magnetic protection alarm
51	Alar PCom Over-H	Power Componet overheat Alarm
52	Alarm Ac Over-C	AC Input Overcurrent Alarm
53	EEPROM Alarm	EEPROM Error
54	Comm. & 1# Err	Compressor & 1# Communication Error
55	Disc Tp Over-H	Exhaust temperature OverHeat
56	Cool Antif	Antifreeze protection in Cooling Mode
57	Plate in Antif	Plate heat exchanger Antifreeze in Cooling Mode
58	HP Protect	Compressor Low Pressure Protection
59	LP Protect	Compressor High Pressure Protection
60	Flow Switch fail	Flow Switch Error
61	Host&HMI CommErr	Communication Err between Indoor Unit and Main Wired Controller
62	WaterPressurePro	Insufficient water pressure protection
63	2# Sensor Er	Zone 2 Temp Sensor Error
64	Econ Sensor Err	Econ Sensor Error
65	Flow SW Protect	Flow SW Protect
66	1#fan Err	#1 Fan Motor Error
67	2#fan Err	#2 Fan Motor Error

## Installation Record

Machine serial number ( on the machine side ) _____
Installation Date:
Installation engineers Name:
The outdoor unit installation location : _____
pipe connections
● refrigerant pipe connection _____
● vacuum <input type="checkbox"/> Complete <input type="checkbox"/> Incomplete
● Leak test <input type="checkbox"/> YES <input type="checkbox"/> NO
electrical connection
● outdoor unit power line <input type="checkbox"/> connection <input type="checkbox"/> No connection
● zero line <input type="checkbox"/> Complete <input type="checkbox"/> Incomplete
● ground line <input type="checkbox"/> Complete <input type="checkbox"/> Incomplete
● indoor unit power line <input type="checkbox"/> Complete <input type="checkbox"/> Incomplete
● indoor and outdoor communication lines <input type="checkbox"/> Complete <input type="checkbox"/> Incomplete
sensor installation
Sensor name _____ installation location _____ (more than one)
1
2
3
4
5
Other control lines name _____
installation location _____ (more than one)
1
2
3
4
5

Maintenance record	
Date:	
Content:	
Result:	
Maintenance personnel signature:	

Maintenance record	
Date:	
Content:	
Result:	
Maintenance personnel signature:	

Maintenance record	
Date:	
Content :	
Result:	
Maintenance personnel signature:	

Maintenance record	
Date:	
Content:	
Result:	
Maintenance personnel signature:	