

New perspectives with
Danfoss Saginomiya Electronic Expansion Valves

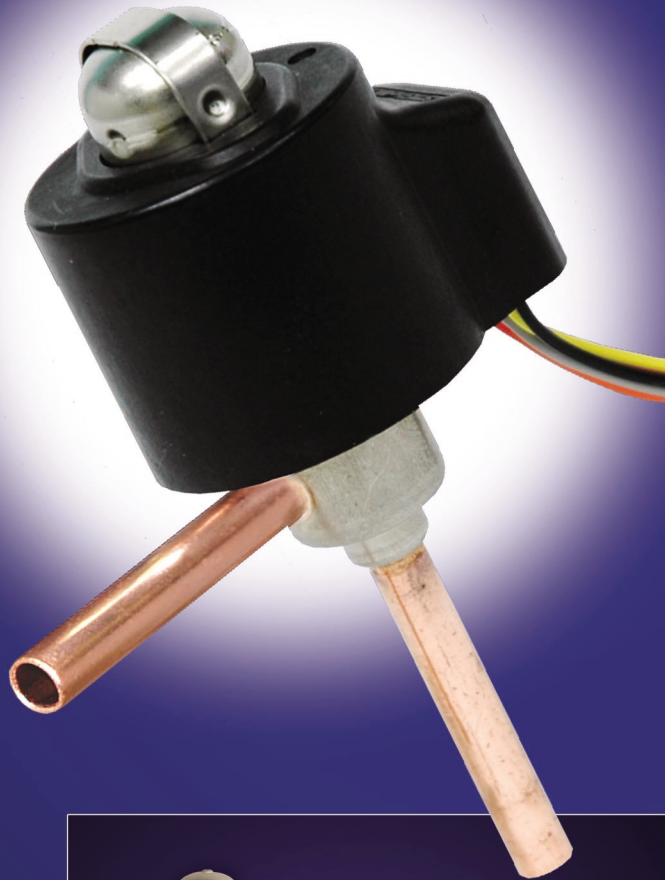

The precise step to take

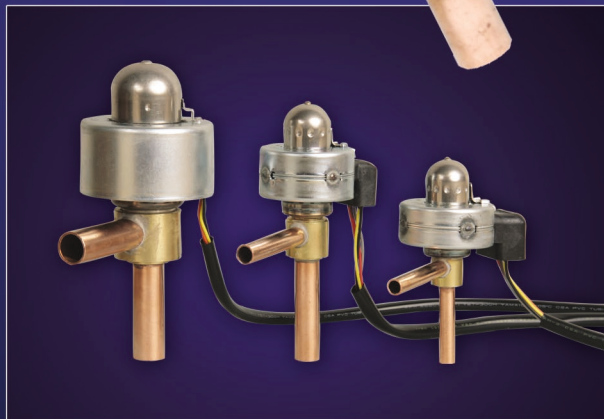

Type KV Electronic Expansion Valves

- Energy efficiency
- Precision flow control with high resolution
- Compact and lightweight
- Power saving design
- Proven know-how and high reliability
- Wide range for all common refrigerants (R410A, R407C, R404A, R134A, R22) as well as CO₂
- Bi-flow for heat pump applications

General description & background

In response to the market shift in the early 80's, to variable speed compressors and an increased consciousness for energy efficiency, Saginomiya introduced the KV range of stepper motor electronic expansion valves. With over 30 years of experience and know-how the current range of Danfoss Saginomiya valves offer high reliability and precise solutions for expansion and flow control in a wide range of refrigeration and air conditioning systems.

Compact and lightweight, the current range are available with different capacities, and can be used with all common refrigerants (R410A, R407C, R404A, R134A, R22) Bi-flow operation is also possible for heat pump systems.

A special high temperature range is also available, especially for applications such as hot gas by-pass.

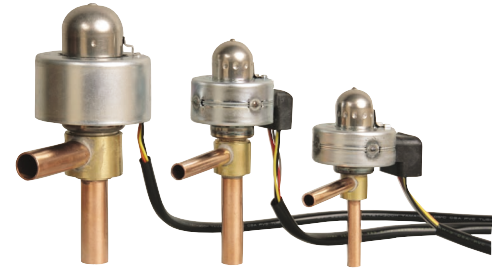

In addition to this, a new range of KV valves is also available for trans-critical CO₂ applications.

The valve design uses uni-polar drives, and different control solutions exist that are compatible with uni-polar drives. Please, contact Danfoss Saginomiya for more details.

Construction & principles of operation

The KV electronic expansion valves open and close to regulate refrigerant flow by means of a screw structure which has linear motion. This occurs by the rotation of a magnet-needle valve assembly which moves when electrical signals are applied to the surrounding coil.

Within the coil structure, there are different winding configurations, and the polarities are

changed by the electrical signals applied. By application of the appropriate combination of signals, in the form of pulses, the coil forces the rotor of the valve to move in a stepwise fashion. Application of multiple pulses will make the valve mechanism move through a series of steps in the direction of choice, in order for the valve to adopt the required position.

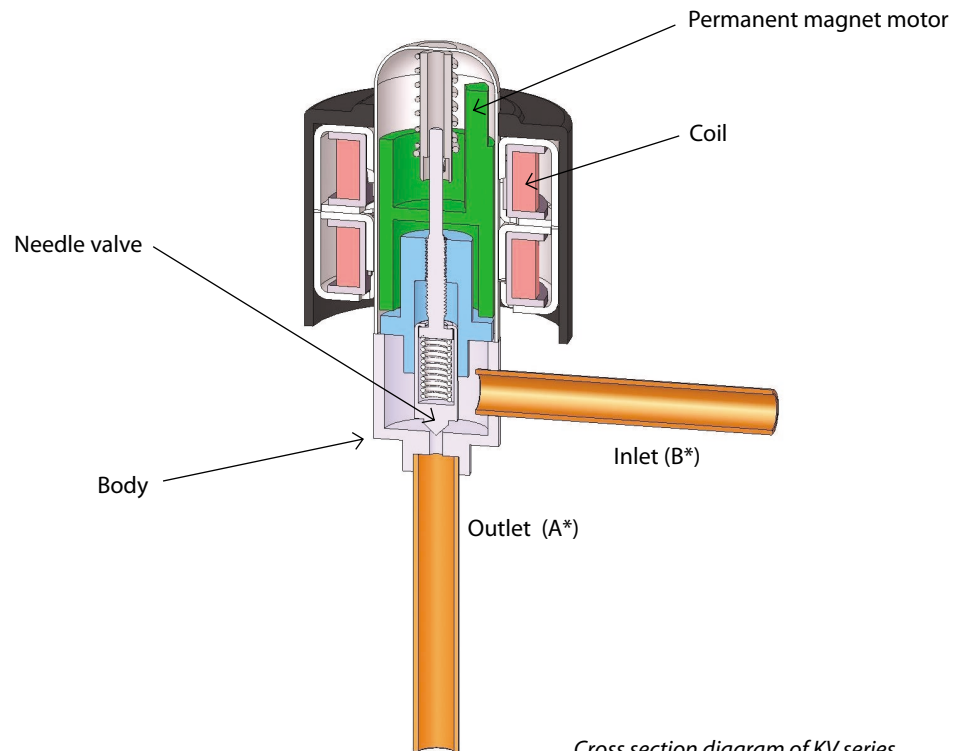

Cross section diagram of KV series
* Refers to refrigerant flow in cooling mode

Technical data

Standard models

Maximum working pressure:	45 bar (150 bar for CO ₂ models)
Compatible refrigerants:	R22, R134A, R404A, R407C, R410A and R744 for CO ₂ models
Ambient temperature:	-30°C to 60°C (-30°C to 70°C for CO ₂ models)
Fluid Temperature:	UKV *: -30°C to 70°C UKV-J: -30°C to 70°C JKV: -30°C to 70°C VKV: -30°C to 120°C (-30°C to 70°C for VKV-40D61) AKV: -30°C to 130°C
	* models for special high temperature applications (up to 120°C) available upon request
Durability:	30 Million total pulses supplied to the valve during operation. (for example this is comparable to 150,000 operations if the valve is operated between 100 to 300 pulses)
Excitation speed:	min. 30 pps (pulses per second) to max. 80 pps, recommended 31,3 pps (50 pps for VKV-40D61)
Modulation:	Permanent magnet type direct operating stepper motor
Operating range:	0 to 480 pulses, no holding power required (NOTE: do not apply more than 520 pulses)
Full motion transit time:	e.g. 16 sec @ 30 pps, 6 sec @ 80 pps
Installation position:	with coil on the upper side and the valve/ coil assembly within +/- 15° of the vertical axis
Ambient humidity:	95% RH or less
Excitation method:	1-2 phase
Electrical connection:	JST XHP-6
Max. coil temperature:	115°C



Valve Specifications

Model No.	Code No.	Orifice [mm]	Nominal Capacity [kW]						Connection (solder)		MWP [bar]	MOPD [bar]	Max. Reverse Pressure [bar]	Flow direction characteristic	Qty per box
			R22	R134a	R404A	R407C	R410A	R744	A [mm]	B [mm]					
UKV-10D85	061L4176	1,0	2,6	2,0	1,8	2,7	3,1	-	7,94	7,94	45	35	35	bi-flow [page 5]	100
UKV-10D85	061L4188	1,0	2,6	2,0	1,8	2,7	3,1	-	7,94	7,94	45	35	35	bi-flow [page 5]	4
UKV-14D69	061L4177	1,4	5,8	4,5	4,1	5,9	6,8	-	7,94	7,94	45	35	20	bi-flow [page 5]	100
UKV-14D69	061L4189	1,4	5,8	4,5	4,1	5,9	6,8	-	7,94	7,94	45	35	20	bi-flow [page 5]	4
UKV-18D02	061L4148	1,8	10,3	8,1	7,3	10,6	12,1	-	6,35	6,35	45	35	28	bi-flow [page 5]	100
UKV-18D51	061L4165	1,8	10,3	8,1	7,3	10,6	12,1	-	6,35	6,35	45	35	28	bi-flow [page 5]	100
UKV-18D51	061L4190	1,8	10,3	8,1	7,3	10,6	12,1	-	6,35	6,35	45	35	28	bi-flow [page 5]	4
VKV-20D32	061L4122	2,0	12,4	9,7	8,7	12,7	14,5	-	7,94	7,94	45	35	24	bi-flow [page 5]	100
UKV-25D57	061L4140	2,5	19,6	15,3	13,8	20,1	23,0	-	7,94	7,94	45	35	22	bi-flow [page 6]	100
UKV-25D57	061L4191	2,5	19,6	15,3	13,8	20,1	23,0	-	7,94	7,94	45	35	22	bi-flow [page 6]	4
UKV-30D59	061L4166	3,0	26,8	20,9	18,9	27,5	31,5	-	7,94	7,94	45	28	15	bi-flow [page 6]	100
UKV-30D59	061L4213	3,0	26,8	20,9	18,9	27,5	31,5	-	7,94	7,94	45	28	15	bi-flow [page 6]	4
UKV-32D61	061L4167	3,2	28,8	22,5	20,3	29,6	33,9	-	7,94	7,94	45	28	12	bi-flow [page 6]	100
UKV-32D61	061L4214	3,2	28,8	22,5	20,3	29,6	33,9	-	7,94	7,94	45	28	12	bi-flow [page 6]	4
VKV-40D61	061L4168	4,0	46,4	36,2	32,7	47,6	54,5	-	12,7	12,7	45	25	3	bi-flow [page 6]	50
AKV-55D03	061L4117	5,5	83,4	65,2	58,8	85,6	98,1	-	15,88	15,88	45	25	7	bi-flow [page 6]	20
UKV-J14D04	061L4155	1,4	-	-	-	-	-	11,2	6,35	6,35	150	100	-	single (B→A) [page 7]	100
JKV-20D29	061L4169	2,0	-	-	-	-	-	20,5	7,94	7,94	150	100	-	single (B→A) [page 7]	80
JKV-24D27	061L4170	2,4	-	-	-	-	-	28,9	7,94	7,94	150	100	-	single (B→A) [page 7]	80

Nominal Capacity based on:

R410A: CT=38 degC, ET=5 degC, SC=0 degC, SH=0 degC, R744: CT=38 degC, CP=100 bar, ET=0 degC



Coil Specifications

Model No.	Code No.	Relevant valve model	Voltage (current)	Cable length [m]	Protective tube length [m]	Enclosure	Insulation class	Qty per box
VKV-MOZS330E0	061L4114	Coil for VKV-20D and JKV-20D valves	12 VDC (0,26A/phase)	0.7	0.5	IP 66	Class "E"	50
VKV-MOZS243B0	061L4171	Coil for VKV-40D and JKV-24D valves	12 VDC (0,38A/phase)	0.7	0.5	IP 66	Class "E"	50
UKV-A102	061L4181	Coil for UKV valves	12 VDC (0,26A/phase)	0.7	0.6	IP 66	Class "E"	100
UKV-A102	061L4192	Coil for UKV valves	12 VDC (0,26A/phase)	0.7	0.6	IP 66	Class "E"	4
AKV-MOZS816B0	061L4119	Coil for AKV valves	12 VDC (0,38A/phase)	0.7	0.5	IP 66	Class "E"	20
UKV-A111	061L4178	Coil for UKV-J valves	12 VDC (0,26A/phase)	0.7	0.6	IP 66	Class "E"	100

Application example

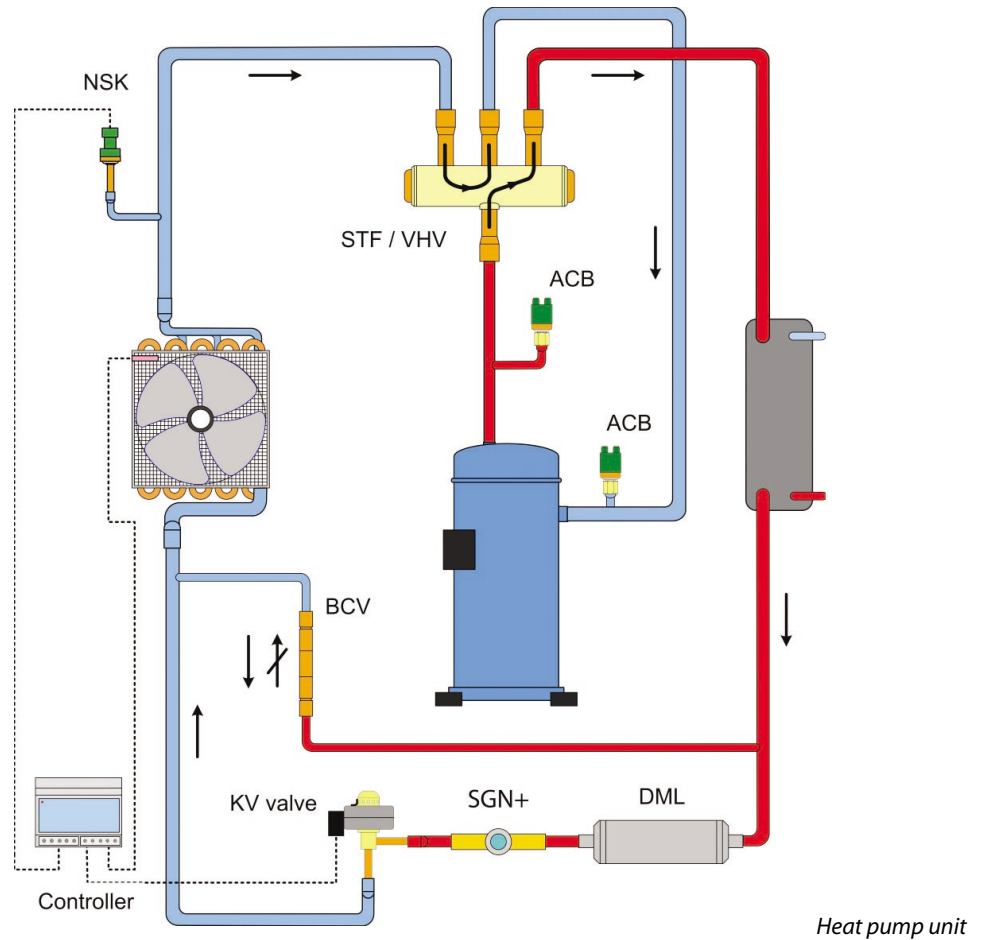

Selection method

If the operating conditions of the unit are known, a KV valve can be selected easily according to the required capacity.

To select the correct electronic expansion valve, it is recommended to define the maximum and minimum refrigeration capacity of the unit. It could be assumed that maximum capacity is required just after starting and the minimum just after stopping operation.

In order to calculate the required maximum and minimum capacity, please refer to the tables (pages 5 or 6) for a correction factor

corresponding to actual evaporating, condensing and subcool temperatures. Then divide the unit's minimum and maximum capacity by the correction factor, to obtain the required capacities of the valve. Choose the valve for which the number of steps between maximum and minimum capacity is the widest to ensure a sufficient resolution and precision in controlling the capacity.

For more details with respect to CO₂ models, please, contact Danfoss Saginomiya.

Capacity for R410A

Evaporating temp.: -25°C
 Condensing temp.: 40°C
 Sub cool: 0°C
 Superheat: 5°C

[kW]

Correction factor table

Superheat: 5°C

Evaporating temp. [°C]	Condensing temp. [°C]	Sub cool [°C]						
		0	10	20	30	40	50	60
-60	50	0.87	1.06	1.23	1.40	1.57	1.73	1.89
	45	0.91	1.08	1.24	1.40	1.56	1.71	1.86
	30	0.94	1.09	1.24	1.39	1.54	1.68	1.82
	35	0.95	1.10	1.24	1.37	1.51	1.64	1.77
	30	0.96	1.09	1.22	1.35	1.48	1.60	1.72
-50	50	0.91	1.09	1.27	1.44	1.60	1.77	1.93
	45	0.94	1.11	1.27	1.43	1.59	1.74	1.89
	30	0.97	1.12	1.27	1.42	1.56	1.70	1.84
	35	0.98	1.12	1.26	1.40	1.53	1.66	1.79
	30	0.98	1.11	1.24	1.37	1.49	1.62	1.74
-40	50	0.93	1.12	1.29	1.46	1.63	1.79	1.95
	45	0.97	1.14	1.30	1.45	1.61	1.76	1.91
	40	0.99	1.14	1.29	1.44	1.58	1.72	1.86
	35	1.00	1.14	1.28	1.41	1.54	1.67	1.80
	30	1.00	1.13	1.25	1.38	1.50	1.62	1.74
-30	50	0.96	1.14	1.31	1.48	1.64	1.80	1.96
	45	0.98	1.15	1.31	1.46	1.61	1.76	1.91
	40	1.00	1.15	1.30	1.44	1.58	1.72	1.85
	35	1.00	1.14	1.28	1.41	1.54	1.67	1.79
	30	1.00	1.12	1.25	1.37	1.49	1.61	-
-25	50	0.96	1.14	1.31	1.48	1.64	1.80	1.95
	45	0.99	1.15	1.31	1.46	1.61	1.76	1.90
	40	1.00	1.15	1.29	1.44	1.57	1.71	1.84
	35	1.00	1.14	1.27	1.40	1.53	1.65	-
	30	0.99	1.12	1.24	1.36	1.48	1.59	-
-20	50	0.96	1.14	1.31	1.48	1.64	1.79	1.95
	45	0.99	1.15	1.31	1.46	1.60	1.75	1.89
	40	1.00	1.15	1.29	1.43	1.56	1.70	-
	35	1.00	1.13	1.26	1.39	1.51	1.64	-
	30	0.98	1.10	1.22	1.34	1.46	-	-
-15	50	0.96	1.14	1.31	1.47	1.63	1.78	1.93
	45	0.98	1.14	1.30	1.45	1.59	1.73	-
	40	0.99	1.14	1.28	1.41	1.55	1.68	-
	35	0.98	1.12	1.24	1.37	1.49	-	-
	30	0.97	1.09	1.20	1.32	1.43	-	-
-10	50	0.96	1.14	1.30	1.46	1.61	1.77	-
	45	0.98	1.13	1.28	1.43	1.57	1.71	-
	40	0.98	1.12	1.26	1.39	1.52	-	-
	35	0.97	1.10	1.22	1.34	1.46	-	-
	30	0.94	1.06	1.17	1.28	-	-	-
-5	50	0.95	1.12	1.29	1.44	1.59	1.74	-
	45	0.96	1.12	1.26	1.41	1.55	-	-
	40	0.96	1.10	1.23	1.36	1.49	-	-
	35	0.94	1.07	1.19	1.31	-	-	-
	30	0.92	1.03	1.13	1.24	-	-	-
0	50	0.94	1.11	1.27	1.42	1.57	-	-
	45	0.95	1.10	1.24	1.38	1.51	-	-
	40	0.94	1.07	1.20	1.32	-	-	-
	35	0.91	1.03	1.15	1.26	-	-	-
	30	0.88	0.98	1.09	-	-	-	-
5	50	0.92	1.08	1.24	1.38	1.53	-	-
	45	0.92	1.07	1.20	1.34	-	-	-
	40	0.91	1.03	1.16	1.28	-	-	-
	30	0.87	0.99	1.10	-	-	-	-
	35	0.83	0.93	1.02	-	-	-	-

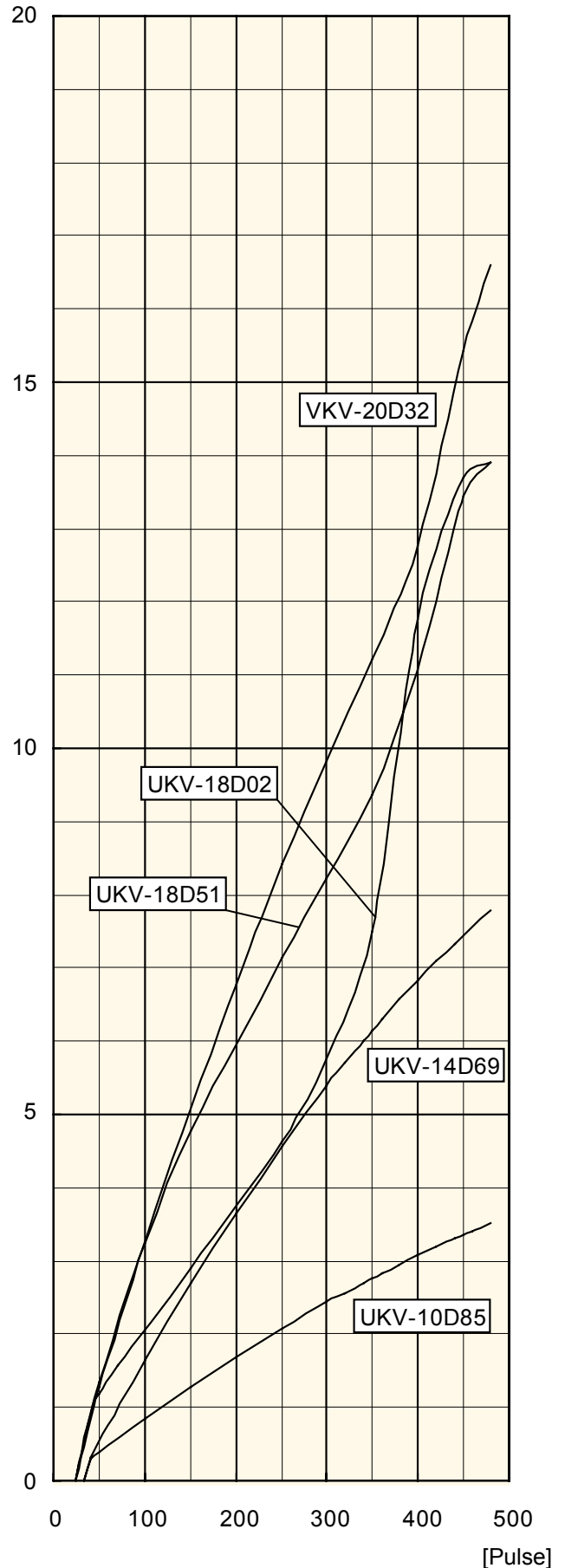

Capacity for R410A

Evaporating temp.: -25°C
 Condensing temp.: 40°C
 Sub cool: 0°C
 Superheat: 5°C

[kW]

Correction factor table

Superheat: 5°C

Evaporating temp. [°C]	Condensing temp. [°C]	Sub cool [°C]							
		0	10	20	30	40	50	60	
-60	50	0.87	1.06	1.23	1.40	1.57	1.73	1.89	
	45	0.91	1.08	1.24	1.40	1.56	1.71	1.86	
	30	0.94	1.09	1.24	1.39	1.54	1.68	1.82	
	35	0.95	1.10	1.24	1.37	1.51	1.64	1.77	
	30	0.96	1.09	1.22	1.35	1.48	1.60	1.72	
-50	50	0.91	1.09	1.27	1.44	1.60	1.77	1.93	
	45	0.94	1.11	1.27	1.43	1.59	1.74	1.89	
	30	0.97	1.12	1.27	1.42	1.56	1.70	1.84	
	35	0.98	1.12	1.26	1.40	1.53	1.66	1.79	
	30	0.98	1.11	1.24	1.37	1.49	1.62	1.74	
-40	50	0.93	1.12	1.29	1.46	1.63	1.79	1.95	
	45	0.97	1.14	1.30	1.45	1.61	1.76	1.91	
	40	0.99	1.14	1.29	1.44	1.58	1.72	1.86	
	35	1.00	1.14	1.28	1.41	1.54	1.67	1.80	
	30	1.00	1.13	1.25	1.38	1.50	1.62	1.74	
-30	50	0.96	1.14	1.31	1.48	1.64	1.80	1.96	
	45	0.98	1.15	1.31	1.46	1.61	1.76	1.91	
	40	1.00	1.15	1.30	1.44	1.58	1.72	1.85	
	35	1.00	1.14	1.28	1.41	1.54	1.67	1.79	
	30	1.00	1.12	1.25	1.37	1.49	1.61	-	
-25	50	0.96	1.14	1.31	1.48	1.64	1.80	1.95	
	45	0.99	1.15	1.31	1.46	1.61	1.76	1.90	
	40	1.00	1.15	1.29	1.44	1.57	1.71	1.84	
	35	1.00	1.14	1.27	1.40	1.53	1.65	-	
	30	0.99	1.12	1.24	1.36	1.48	1.59	-	
-20	50	0.96	1.14	1.31	1.48	1.64	1.79	1.95	
	45	0.99	1.15	1.31	1.46	1.60	1.75	1.89	
	40	1.00	1.15	1.29	1.43	1.56	1.70	-	
	35	1.00	1.13	1.26	1.39	1.51	1.64	-	
	30	0.98	1.10	1.22	1.34	1.46	-	-	
-15	50	0.96	1.14	1.31	1.47	1.63	1.78	1.93	
	45	0.98	1.14	1.30	1.45	1.59	1.73	-	
	40	0.99	1.14	1.28	1.41	1.55	1.68	-	
	35	0.98	1.12	1.24	1.37	1.49	-	-	
	30	0.97	1.09	1.20	1.32	1.43	-	-	
-10	50	0.96	1.14	1.30	1.46	1.61	1.77	-	
	45	0.98	1.13	1.28	1.43	1.57	1.71	-	
	40	0.98	1.12	1.26	1.39	1.52	-	-	
	35	0.97	1.10	1.22	1.34	1.46	-	-	
	30	0.94	1.06	1.17	1.28	-	-	-	
-5	50	0.95	1.12	1.29	1.44	1.59	1.74	-	
	45	0.96	1.12	1.26	1.41	1.55	-	-	
	40	0.96	1.10	1.23	1.36	1.49	-	-	
	35	0.94	1.07	1.19	1.31	-	-	-	
	30	0.92	1.03	1.13	1.24	-	-	-	
0	50	0.94	1.11	1.27	1.42	1.57	-	-	
	45	0.95	1.10	1.24	1.38	1.51	-	-	
	40	0.94	1.07	1.20	1.32	-	-	-	
	35	0.91	1.03	1.15	1.26	-	-	-	
	30	0.88	0.98	1.09	-	-	-	-	
5	50	0.92	1.08	1.24	1.38	1.53	-	-	
	45	0.92	1.07	1.20	1.34	-	-	-	
	40	0.91	1.03	1.16	1.28	-	-	-	
	30	0.87	0.99	1.10	-	-	-	-	
	35	0.83	0.93	1.02	-	-	-	-	

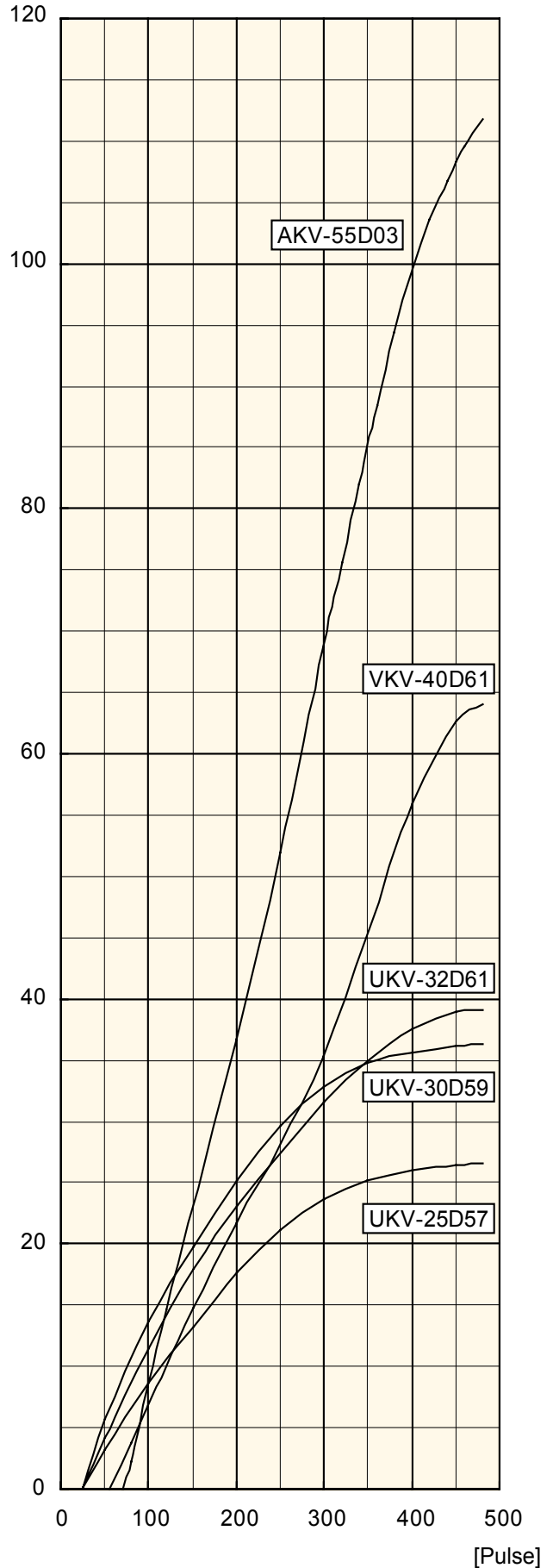

Capacity for R744 (CO₂)

Evaporating temp.: 5°C
Condensing temp.: 38°C
Condensing pressure: 100 bar

[kW]

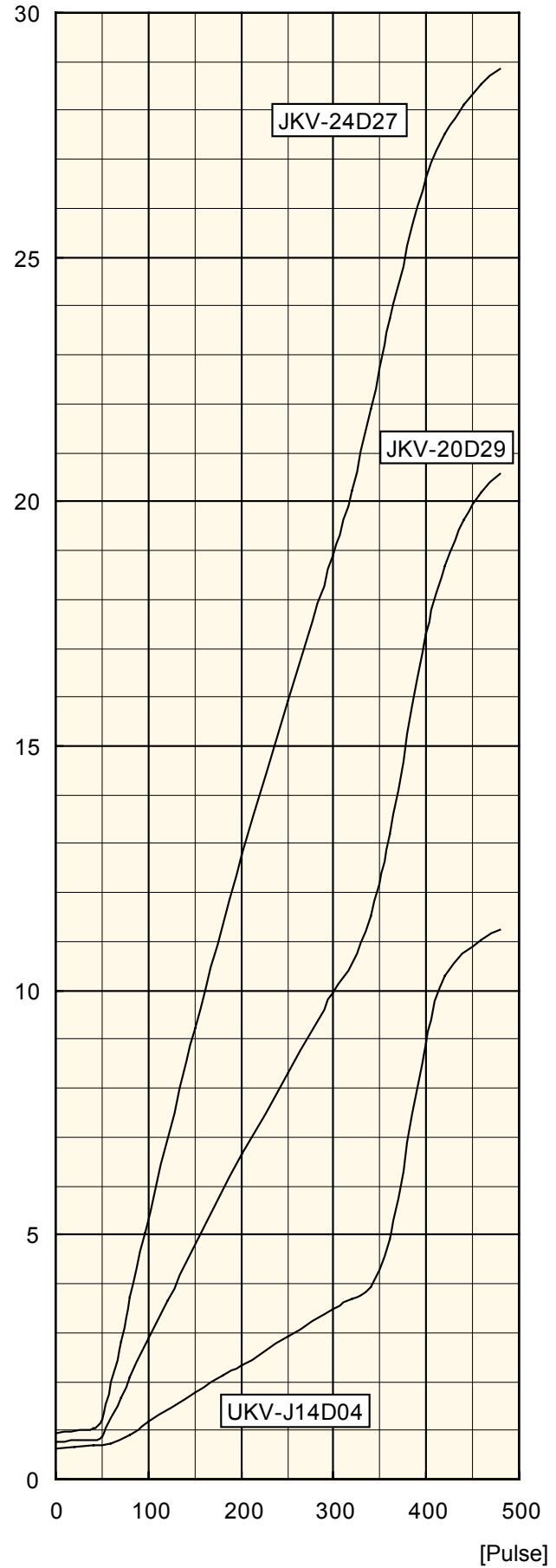

Dimensions

UKV

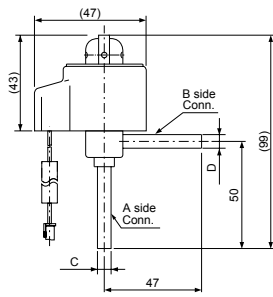

Model No.	C	D
UKV-10D85	φ 7.94	
UKV-14D69		
UKV-18D51	φ 6.35	
UKV-25D57	φ 7.94	
UKV-30D59		
UKV-32D61		

UKV-18D02

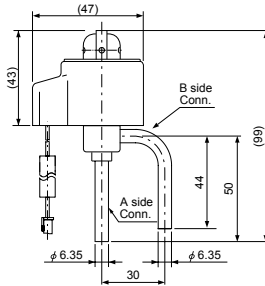

VKV-20D

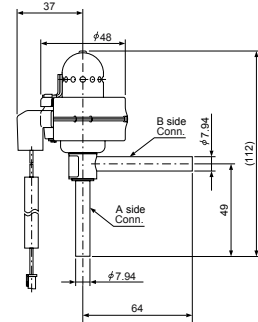

VKV-40D

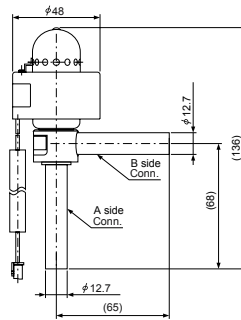

AKV-55D

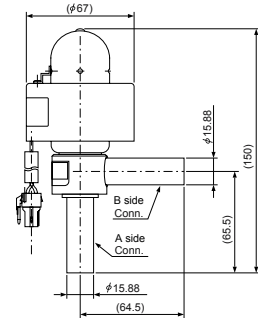

UKV-J

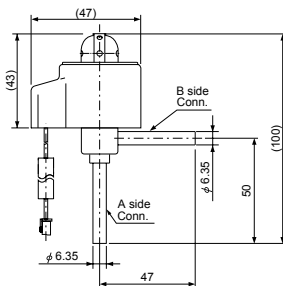

JKV-20D

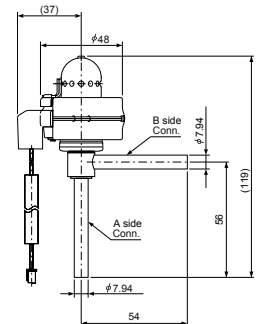

JKV-24D

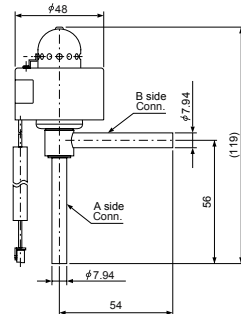

Danfoss / Danfoss Saginomiya can accept no responsibility for possible errors in catalogues, brochures and other printed material. Danfoss / Danfoss Saginomiya reserves the right to alter its products without notice. This also applies to products already on order provided that such alterations can be made without subsequent changes being necessary in specifications already agreed. All trademarks in this material are property of the respective companies. Danfoss / Danfoss Saginomiya and Saginomiya and the logotypes are trademarks of Danfoss A/S and Saginomiya. All rights reserved.