

# Electrically operated expansion valves, type ETS

## Introduction

ETS is a series of electrically operated expansion valves for precise liquid injection in evaporators for air conditioning and refrigeration applications.

The valve piston and linear positioning design is fully balanced, providing bi-flow feature as well as solenoid tight shut-off function in both flow directions.

The ETS needs a current or voltage driver as partner to be operated.

EKC316A, 312 and EKD316 are examples of Danfoss controllers with drivers matching the ETS needs.

The ETS design is being registered. The pending reference number is 200530003728.1.



## Features

- Precise positioning for optimal control of liquid injection.
- ETS 12,5, ETS 25, ETS 50 and ETS 100 are designed for HFC/HCFC conditions including R410A, providing 45.5 bar (659.9 psig) working pressure.  
ETS 250 and 400 are designed for HFC/HCFC conditions, providing 34 bar (493 psig) working pressure.
- Balanced design providing bi-flow operation as well as solenoid tight shut-off function in both flow directions at MOPD 33 bar (478.6 psig).
- EKC316A, 312 and EKD316 are examples of Danfoss controllers with drivers matching the ETS needs.
- ETS 50 and 100 have bi-metal connections providing "waterless brazing", improved process and productivity.
- ETS 50 to 400 are all designed with built-in sight glass.
- Cable and connector assemblies as accessories.
- For manual operation and service of ETS valves an AST-g service driver is available. For further information please contact Danfoss.

Technical data

Parameter	
Compatibility	HFC, HCFC
CE marking	Yes
MOPD	33 bar (478.6 psi)
Max. working pressure (PS/MWP)	ETS12.5/ETS25/ETS50/ETS100: 45.5 bar (659.9 psi) ETS 250/ETS 400:34 bar (493 psi)
Refrigerant temperature range	-40°C to 10°C (-40°F to 50°F)
Ambient temperature	-40°C to 60°C (-40°F to 140°F)
Motor enclosure	IP 67
Stepper motor type	Bi-polar - permanent magnet
Step mode	2 phase full step
Phase resistance	52Ω ±10%
Phase inductance	85 mH
Holding current	Depends on application. Full current allowed (100% duty cycle)
Step angle	7.5° (motor), 0.9° (lead screw), Gearing ration 8.5:1. (38/13) <sup>2</sup> :1
Nominal voltage	(Constant voltage drive) 12 V dc -4% +15%, 150 steps/sec.

Parameter	
Phase current	(Using chopper drive) 100 mA RMS -4% +15%,
Max. total power	Voltage / current drive: 5.5 / 1.3 W (UL: NEC class 2)
Step rate	150 steps/sec. (constant voltage drive) 0-300 steps/sec. 300 recommended (chopper current drive)
Total steps	ETS 25, 12°: 2625 [+160 / -0] steps ETS 50: 2625 [+160 / -0] steps ETS 100: 3530 [+160 / -0] steps ETS 250 and 400: 3810 [+160 / -0] steps
Full travel time	ETS 25, 12°: 17 / 8.5 sec. (voltage / current) ETS 50: 17 / 8.5 sec. (voltage / current) ETS 100: 23 / 11.5 sec. (voltage / current) ETS 250 and 400: 25.4 / 12.7 sec. (voltage / current)
Lifting height	ETS 25, 12°: 13 mm (0.5 in.) ETS 50: 13 mm (0.5 in.) ETS 100: 16 mm (0.6 in.) ETS 250-400: 17.2 mm (0.7 in.)
Reference position	Overdriving against the full close position
Electrical connection	M12 connector

Electrical wiring

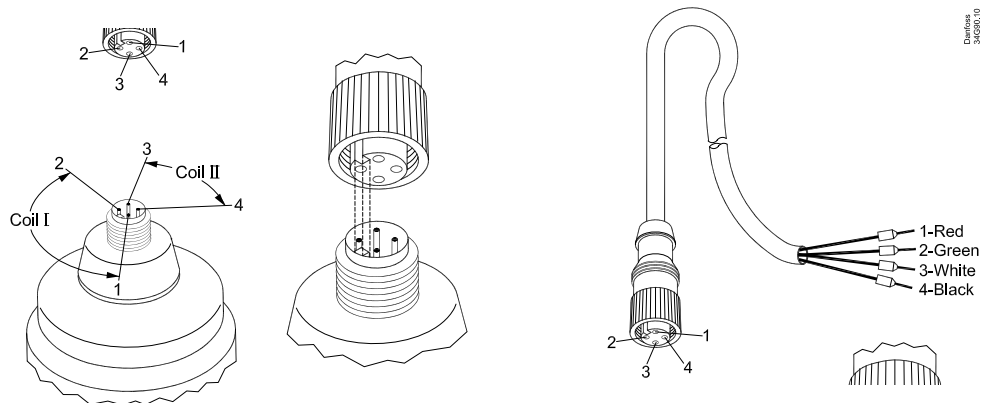

Check

Electrically check of stepper motor and wiring. Coil I = 52 ohm - coil II 52 ohm

Stepper motor switch sequence

	STEP	Coil I		Coil II		
		Red	Green	White	Black	
↑ CLOSING ↑	1	+	-	+	-	↓ OPENING ↓
	2	+	-	-	+	
	3	-	+	-	+	
	4	-	+	+	-	
	1	+	-	+	-	

Design

Valve / Actuator type ETS / AST-g

ETS 25, 12½, straight and angleway

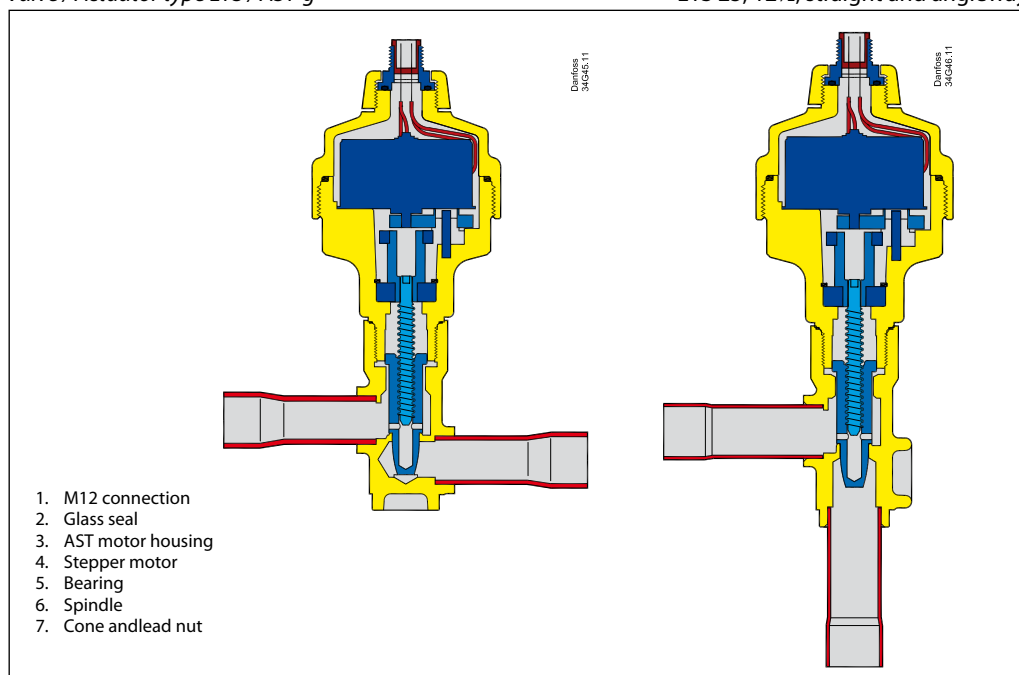

1. M12 connection
2. Glass seal
3. AST motor housing
4. Stepper motor
5. Bearing
6. Spindle
7. Cone and lead nut

Valve operation

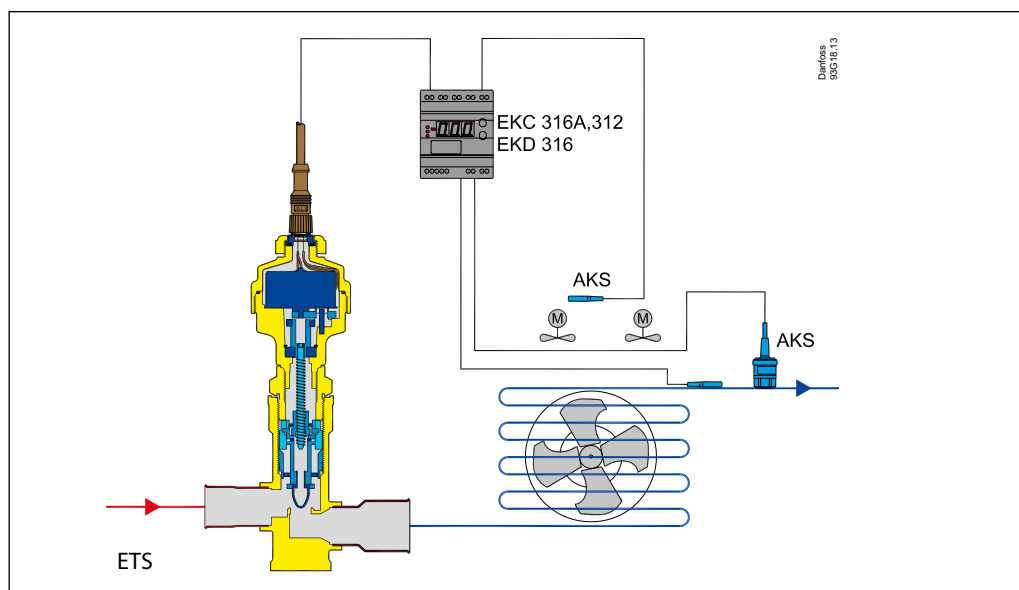

The ETS valves operate modulating by electronically controlled activation of the AST stepper motor. The motor is a type 2-phase bi-polar, which stays in position, unless power pulses from a driver initiate the two discrete sets of motor stator windings for rotation in either directions.

The direction depends on the phase relationship of the power pulses, which number again is decisive for the travel.

The motor is operating the spindle, which rotating movements are transformed into linear motion by the transmission in the cage assembly.

The AST motor housing has a glass sealed M12 connection as standard, which can be connected with customized cable and plug/socket combinations.

ETS design is fully power balanced, giving identical bi-flow performance capabilities and nearby identical maximum capacities.

The port design includes a shut-off function with "solenoid" tightness in both flow directions. Closed position is also the mechanical stop acting as reference point to reset the controller.

Operating the ETS series requires a controller with either 12 V dc voltage drive (5.5 W) or using chopper drive (100 mA RMS).

Danfoss EKC316A, EKC312 and EED316 are examples of qualified controllers.

Valve operation (Cont.)

**Note:**  
Depending on the type of controller or rather driver, there will be limitations in cable length between valve actuator and driver.

In all these controllers a 10 mH filter type AKA 211 can be installed on the four power terminals that can increase the maximum cable length considerably.

Both the actual cable length, the level of EMC emission on the location and driver circuit has an impact on the actual distortion of the current to the actuator motor.

Please contact Danfoss for further information how and when to apply this countermeasure in cases with questionable cable length.

For the Danfoss controllers the rule of thumb is maximum 5 m [15 feet] for EKC316 and 312 and 50 m [150 feet] for EKD316.

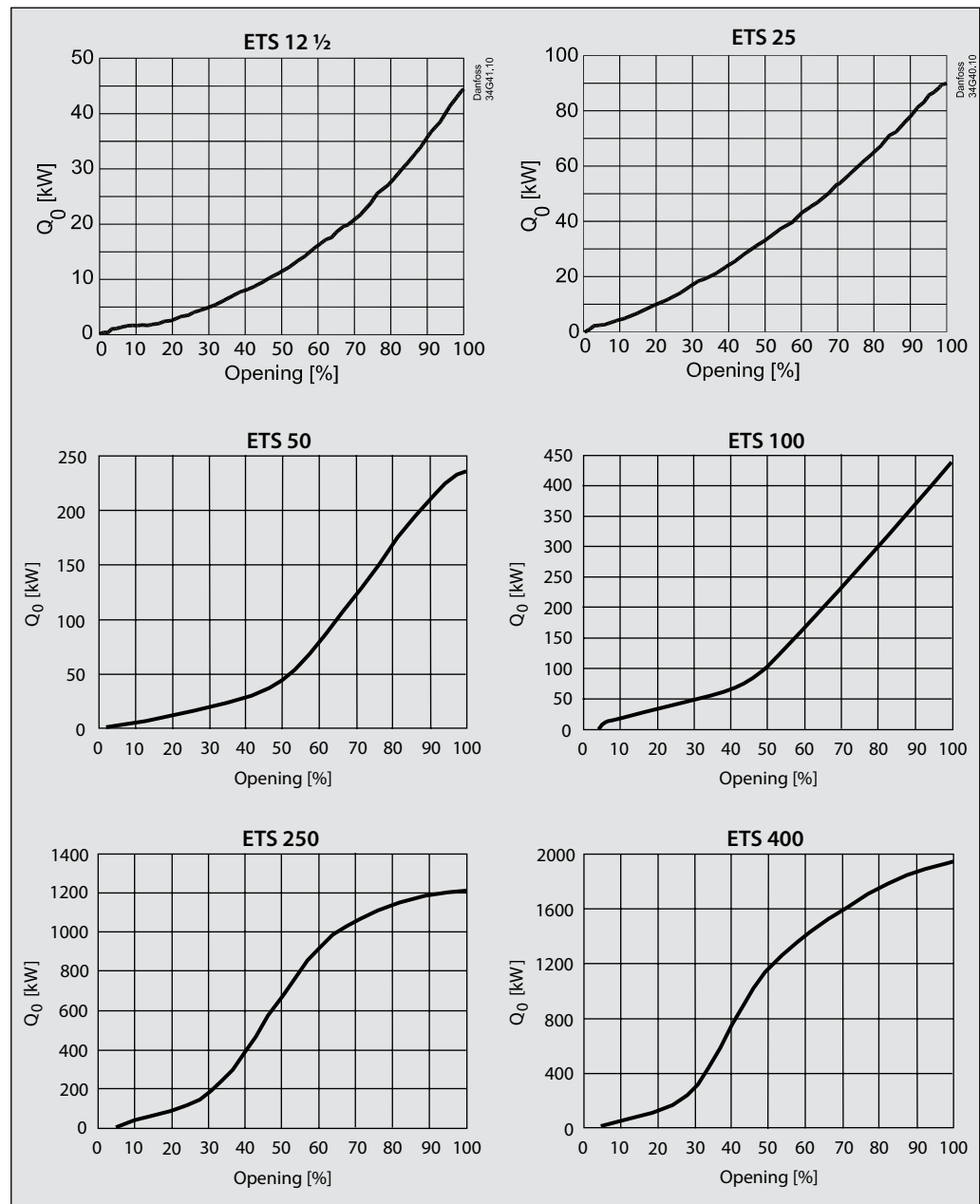

Capacity based on:  
R407C  
 $T_e = 5^\circ\text{C}$  (41°F)  
 $T_c = 32^\circ\text{C}$  (89.6°F)  
 $T_i = 28^\circ\text{C}$  (82.4°F)

**Sizing**

*Correction for subcooling  $\Delta t_{sub}$*

The evaporator capacity used must be corrected if subcooling deviates from 4K (7.2°F). The corrected capacity can be obtained by dividing

the evaporator capacity by the correction factor given below.

**Note:**  
Insufficient subcooling can produce flash gas.

Correction factor	$\Delta t_{sub}$									
	4 K	10 K	15 K	20 K	25 K	30 K	35 K	40 K	45 K	50 K
	7.2°F	18°F	27°F	36°F	45°F	54°F	63°F	72°F	81°F	90°F
R22	1,00	1,06	1,11	1,15	1,20	1,25	1,30	1,35	1,39	1,44
R410A	1,00	1,08	1,15	1,21	1,27	1,33	1,39	1,45	1,50	1,56
R407C	1,00	1,08	1,14	1,21	1,27	1,33	1,39	1,45	1,51	1,57
R134a	1,00	1,08	1,13	1,19	1,25	1,31	1,37	1,42	1,48	1,54
R404A / R507	1,00	1,10	1,20	1,29	1,37	1,46	1,54	1,63	1,70	1,78

**Example:** Refrigerant: R410A

Evaporating temperature:

$t_e = +10^\circ\text{C}$  (50°F)

$p_e = 9.8$  bar (142 psig)

Condensing temperature:

$t_c = 40^\circ\text{C}$  (104°F)

$p_c = 23$  bar (330 psig)

Pressure drop in valve:

$\Delta p = 23 - 9.8 = 13.2$  bar (192 psig)

Subcooling:  $\Delta t_{sub} = 15$  K (27°F)

Evaporator capacity: 500 kW (143 TR)

Correction value from table: 1.15

The corrected evaporator capacity thus becomes  $500 : 1.15 = 435$  kW (124 TR)

As the ETS series has a wide capacity area from the table values down to 10% of these, the sizing is not critical.

Under the given circumstances ETS 100 can operate between 496 kW (142 TR) and 56 kW (14 TR).

Bi-flow capacities (opposite of normal flow direction) are the same for ETS 50, whereas ETS 100 has 10% less from normal flow direction.

**Ordering**

**Valve incl. actuator**

*Single pack*

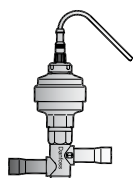

Type	Rated capacity <sup>1)</sup>										Connection			
	R410A		R407C		R22		R134a		R404A		ODF × ODF [in]	ODF × ODF [mm]	Code no. Straight way	Code no. Angle way
	kW	TR	kW	TR	kW	TR	kW	TR	kW	TR				
ETS 12½	70	20	63	18	57	16	45	13	43	12	½ × ½	<del>12 × 12</del>	<b>034G4209</b>	<b>034G4213</b>
											<del>5/8 × 5/8</del>	12 × 12	<b>034G4208</b>	<b>034G4212</b>
											5/8 × 5/8	16 × 16	<b>034G4210</b>	<b>034G4214</b>
											7/8 × 7/8	22 × 22	<b>034G4211</b>	<b>034G4215</b>
ETS 25	144	41	129	37	117	34	93	27	88	25	½ × ½	<del>12 × 12</del>	<b>034G4201</b>	<b>034G4205</b>
											<del>5/8 × 5/8</del>	12 × 12	<b>034G4200</b>	<b>034G4204</b>
											5/8 × 5/8	16 × 16	<b>034G4202</b>	<b>034G4206</b>
											7/8 × 7/8	22 × 22	<b>034G4203</b>	<b>034G4207</b>

*ETS 50 and ETS 100 are delivered with sight glass*

**Valve incl. actuator**

*Single pack*

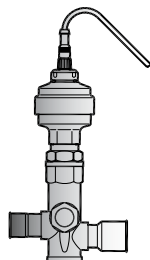

Type	Rated capacity <sup>1)</sup>										Connection [in]		
	R410A		R407C		R22		R134a		R404A		ODF × ODF [in]	ODF × ODF [mm]	Code no. Industrial pack
	kW	TR	kW	TR	kW	TR	kW	TR	kW	TR			
ETS 50	262.3	75.7	240.5	69.1	215	62	170	48.9	161.4	46.3	7/8 × 7/8	22 × 22	<b>034G1708</b>
											7/8 × 1 1/8	22 × 28	<b>034G1705</b>
											1 1/8 × 1 1/8	28 × 28	<b>034G1706</b>
											1 1/8 × 1 3/8	28 × 35	<b>034G1704</b>
ETS 100	488.4	140.9	447.8	128.7	400.4	115.4	316.5	91.2	300.5	86.6	1 1/8 × 1 1/8	28 × 28	<b>034G0507</b>
											1 1/8 × 1 3/8	28 × 35	<b>034G0501</b>
											1 3/8 × 1 3/8	35 × 35	<b>034G0508</b>
											1 5/8 × 1 5/8	<del>28 × 35</del>	<b>034G0505</b>

<sup>1)</sup> The Rated capacity is based on:  
 Evaporating temperature  $t_e$ : 5°C (40°F)  
 Liquid temperature  $t_l$ : 28°C (82°F)  
 Condensing temperature  $t_c$ : 32°C (90°F)  
 Full stroke opening.

Valve incl. actuator  
Single pack

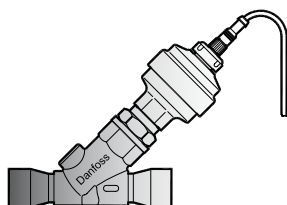

ETS 250 and ETS 400 are delivered with sight glass

Type	Rated capacity <sup>1)</sup>										Connection		
	R410A		R407C		R22		R134a		R404A		ODF × ODF [in.]	ODF × ODF [mm]	Code no. Single pack
	kW	TR	kW	TR	kW	TR	kW	TR	kW	TR			
ETS 250	-	-	1212	349	1106	319	874	252	828	239	1 1/8 × 1 1/8	28 × 28	034G2600
											1 3/8 × 1 3/8	35 × 35	034G2601
											1 5/8 × 1 5/8		034G2602
ETS 400	-	-	1933	556	1764	509	1394	402	1320	381	1 5/8 × 1 5/8		034G3500
											2 1/8 × 2 1/8	54 × 54	034G3501

<sup>1)</sup> The Rated capacity is based on:  
 Evaporating temperature  $t_e$ : 5°C (40°F)  
 Liquid temperature  $t_l$ : 28°C (82°F)  
 Condensing temperature  $t_c$ : 32°C (90°F)  
 Full stroke opening.

ETS for CO<sub>2</sub> Applications

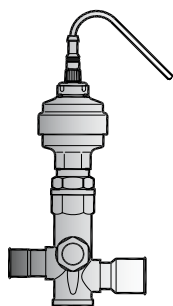

ETS for CO<sub>2</sub> Applications (MWP 45.5 bar / 660 psig)

Type	Connection	
	ODF × ODF [in.]	Code no. Single pack
ETS 12.5	7/8 x 7/8 in	034G4220
ETS 25	7/8 x 7/8 in	034G4219
ETS 50	1 1/8 x 1 1/8 in	034G1714
ETS 100	1 1/8 x 1 1/8 in	034G0515

ETS is for CO<sub>2</sub> used both in Expansion valve mode and gas bypass mode.  
 For capacities, please contact Danfoss.

Accessories

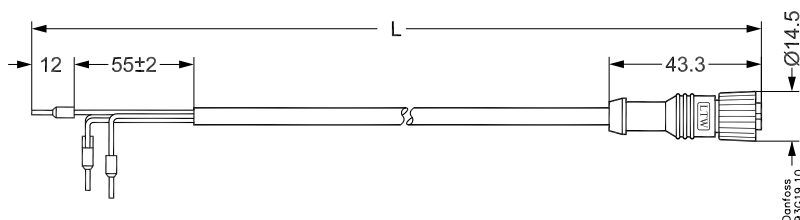

Cable and connector assemblies for ETS with AST-g MK II actuator

Cable quality	Temperature range	Cable length		Design	Code no	
					Single pack	Industrial pack (20 pcs)
Jacket: PVC Insulation: PVC	-50 / +80°C	2 m	6.6 ft	M12, 4 pins to actuator and loose wires for driver connection	034G2201	034G2330
		8 m	26.2 ft		034G2200	034G2323
Jacket: CPE Insulation: EPR	-40 / +80°C	2 m	6.6 ft		034G2202	034G2331

Capacities

Range -40°C to +10°C

SI units

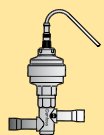
	t <sub>e</sub> [°C]	Rated capacity [kW]															
		ETS 12½								ETS 25							
		Pressure drop Δp [bar]															
		2	4	6	8	10	12	14	16	2	4	6	8	10	12	14	16
R410A	-40	46.4	60.0	68.1	73.5	77.3	79.9	81.6	82.6	95.3	123.2	140.0	151.1	158.8	164.1	167.7	169.8
	-30	45.2	59.0	67.3	73.0	76.9	79.7	81.6	82.7	92.9	121.2	138.4	150.0	158.1	163.8	167.7	170.1
	-20	43.6	57.4	65.9	71.7	75.8	78.7	80.7	82.0	89.6	117.9	135.4	147.4	155.8	161.8	165.9	168.6
	-10	41.6	55.2	63.7	69.6	73.8	76.8	78.9	80.3	85.5	113.5	131.0	143.1	151.7	157.9	162.2	165.0
	-5	40.5	53.9	62.4	68.3	72.5	75.5	77.6	79.0	83.3	110.8	128.2	140.3	149.0	155.2	159.6	162.5
	10	36.7	49.2	57.3	63.0	67.1	70.1	72.2	73.5	75.4	101.2	117.8	129.5	137.9	144.0	148.3	151.2
R407C	-40	42.1	52.8	58.6	62.0	63.9	64.9	65.0	64.6	86.5	108.5	120.5	127.5	131.4	133.3	133.6	132.7
	-30	41.9	53.0	59.2	63.0	65.2	66.3	66.7	66.4	86.0	109.0	121.7	129.4	133.9	136.3	137.1	136.6
	-20	41.2	52.8	59.3	63.4	65.8	67.2	67.8	67.8	84.7	108.5	121.9	130.2	135.3	138.2	139.4	139.3
	-10	40.2	52.0	58.8	63.1	65.9	67.5	68.3	68.4	82.6	106.9	120.9	129.8	135.4	138.7	140.3	140.6
	-5	39.6	51.4	58.4	62.8	65.6	67.3	68.2	68.4	81.3	105.7	120.0	129.0	134.9	138.4	140.2	140.6
	10	37.1	48.9	56.0	60.6	63.7	65.5	66.7	67.1	76.3	100.5	115.0	124.6	130.9	134.8	137.1	138.0
R22	-40	40.2	51.3	57.9	62.1	65.0	66.9	68.0	68.6	82.6	105.5	118.9	127.7	133.6	137.5	139.8	141.1
	-30	39.8	51.3	58.1	62.6	65.7	67.7	69.1	69.8	81.8	105.4	119.4	128.7	135.0	139.2	142.0	143.5
	-20	39.1	50.8	57.9	62.6	65.9	68.1	69.6	70.4	80.3	104.4	118.9	128.7	135.4	140.0	143.0	144.8
	-10	38.0	49.9	57.1	62.1	65.5	67.9	69.5	70.5	78.1	102.5	117.4	127.5	134.6	139.5	142.8	144.9
	-5	37.4	49.3	56.6	61.6	65.1	67.5	69.2	70.2	76.9	101.2	116.3	126.5	133.7	138.8	142.2	144.4
	10	35.2	46.8	54.1	59.2	62.9	65.4	67.2	68.4	72.3	96.2	111.3	121.7	129.2	134.5	138.2	140.6
R134a	-40	35.6	43.2	46.8	48.5	49.0	48.6	47.7	46.3	73.1	88.8	96.3	99.7	100.7	100.0	98.0	95.1
	-30	35.8	44.0	48.0	50.0	50.7	50.6	49.9	48.6	73.5	90.4	98.6	102.7	104.2	104.0	102.5	99.9
	-20	35.6	44.3	48.8	51.1	52.1	52.2	51.7	50.6	73.3	91.1	100.2	105.0	107.0	107.3	106.2	104.0
	-10	35.2	44.3	49.1	51.7	53.0	53.3	53.0	52.1	72.3	91.0	100.9	106.2	108.8	109.6	108.9	107.1
	-5	34.8	44.1	49.0	51.8	53.2	53.7	53.4	52.6	71.6	90.6	100.8	106.4	109.3	110.3	109.8	108.2
	10	33.3	42.8	48.1	51.2	53.0	53.7	53.8	53.2	68.3	88.0	98.9	105.3	108.9	110.4	110.5	109.4
R404A	-40	31.9	39.6	43.4	45.2	45.9	45.8	45.0	43.8	65.7	81.4	89.2	93.0	94.3	94.0	92.5	90.0
	-30	31.5	39.5	43.6	45.8	46.7	46.7	46.2	45.1	64.7	81.2	89.7	94.0	95.9	96.1	94.9	92.8
	-20	30.7	39.0	43.3	45.7	46.9	47.1	46.8	45.9	63.0	80.1	89.1	94.0	96.3	96.9	96.1	94.3
	-10	29.5	37.9	42.5	45.1	46.4	46.9	46.7	45.9	60.7	78.0	87.4	92.7	95.4	96.3	95.9	94.4
	-5	28.9	37.3	41.9	44.6	46.0	46.5	46.3	45.6	59.4	76.6	86.1	91.6	94.5	95.5	95.2	93.8
	10	26.5	34.6	39.2	41.9	43.5	44.1	44.1	43.5	54.4	71.0	80.5	86.2	89.3	90.6	90.6	89.4

Correction for subcooling Δt<sub>sub</sub>

The evaporator capacities used must be corrected if subcooling deviates from 4 K (7.2°F). The corrected capacity can be obtained by

dividing the required evaporator capacity by the correction factor below. Selections can then be made from the tables above.

Correction factor	Δt <sub>sub</sub>									
	4 K	10 K	15 K	20 K	25 K	30 K	35 K	40 K	45 K	50 K
	7.2°F	18°F	27°F	36°F	45°F	54°F	63°F	72°F	81°F	90°F
R22	1.00	1.06	1.11	1.15	1.20	1.25	1.30	1.35	1.39	1.44
R410A	1.00	1.08	1.15	1.21	1.27	1.33	1.39	1.45	1.50	1.56
R407C	1.00	1.08	1.14	1.21	1.27	1.33	1.39	1.45	1.51	1.57
R134a	1.00	1.08	1.13	1.19	1.25	1.31	1.37	1.42	1.48	1.54
R404A / R507	1.00	1.10	1.20	1.29	1.37	1.46	1.54	1.63	1.70	1.78

**Note:** Insufficient subcooling can produce flash gas.

Capacities

Range -40°C to +10°C

SI units

	t <sub>e</sub> [°C]	Rated capacity [kW]															
		ETS 50B								ETS 100B							
		Pressure drop Δp [bar]															
		2	4	6	8	10	12	14	16	2	4	6	8	10	12	14	16
R410A	-40	173,7	224,6	255,1	275,5	289,5	299,2	305,7	309,6	323,5	418,1	475,0	512,9	539,1	557,2	569,2	576,4
	-30	169,3	220,8	252,3	273,5	288,3	298,6	305,7	310,1	315,2	411,2	469,7	509,2	536,8	556,1	569,2	577,5
	-20	163,3	214,9	246,8	268,6	284,1	295,0	302,5	307,4	304,0	400,1	459,6	500,2	528,9	549,2	563,3	572,4
	-10	155,9	206,8	238,8	260,9	276,6	287,9	295,8	301,0	290,3	385,0	444,6	485,7	515,1	536,1	550,8	560,5
	-5	151,7	202,0	233,7	255,8	271,6	283,0	291,0	296,4	282,5	376,0	435,2	476,3	505,8	527,0	541,9	551,8
	10	137,5	184,5	214,8	236,1	251,5	262,7	270,6	275,8	256,0	343,5	399,9	439,6	468,3	489,1	503,8	513,6
R407C	-40	158,5	199,3	222,0	235,6	243,8	248,1	249,7	249,1	295,1	371,2	413,3	438,7	453,9	462,0	464,9	463,8
	-30	157,6	200,3	224,4	239,3	248,5	253,7	256,1	256,2	293,5	373,0	417,8	445,5	462,6	472,5	476,9	477,1
	-20	155,3	199,5	224,9	241,0	251,2	257,3	260,5	261,3	289,2	371,5	418,8	448,7	467,7	479,2	485,1	486,6
	-10	151,7	196,8	223,3	240,4	251,5	258,5	262,5	263,9	282,4	366,4	415,9	447,6	468,4	481,4	488,7	491,4
	-5	149,4	194,7	221,7	239,2	250,8	258,1	262,4	264,2	278,1	362,6	412,8	445,4	466,9	480,6	488,6	491,9
	10	140,7	185,7	213,2	231,6	244,0	252,3	257,4	259,9	261,9	345,7	397,0	431,2	454,4	469,8	479,2	483,9
R22	-40	151,5	193,5	218,1	234,2	245,1	252,2	256,6	258,8	282,1	360,2	406,2	436,2	456,3	469,6	477,7	481,9
	-30	149,9	193,2	218,9	236,0	247,6	255,4	260,4	263,1	279,1	359,7	407,6	439,4	460,9	475,5	484,8	489,9
	-20	147,1	191,3	218,0	235,9	248,2	256,6	262,2	265,5	273,9	356,2	405,9	439,2	462,1	477,9	488,2	494,3
	-10	143,2	187,8	215,2	233,8	246,7	255,7	261,8	265,6	266,6	349,7	400,8	435,3	459,4	476,2	487,5	494,5
	-5	140,8	185,5	213,1	231,9	245,1	254,4	260,7	264,6	262,3	345,4	396,8	431,8	456,4	473,7	485,4	492,8
	10	132,4	176,2	203,9	223,0	236,7	246,5	253,2	257,6	246,5	328,1	379,6	415,3	440,8	458,9	471,5	479,7
R134a	-40	133,1	161,8	175,4	181,6	183,4	182,1	178,6	173,3	247,8	301,3	326,6	338,2	341,5	339,1	332,5	322,6
	-30	133,9	164,7	179,7	187,1	189,9	189,5	186,7	182,1	249,3	306,6	334,6	348,5	353,6	352,8	347,6	339,0
	-20	133,4	166,1	182,6	191,2	195,0	195,4	193,4	189,5	248,4	309,2	340,0	356,0	363,1	363,9	360,1	352,8
	-10	131,7	165,9	183,7	193,5	198,3	199,6	198,3	195,1	245,2	308,8	342,1	360,3	369,2	371,6	369,3	363,3
	-5	130,3	165,1	183,6	193,9	199,2	200,9	200,0	197,1	242,6	307,4	341,9	361,1	370,8	374,1	372,4	367,0
	10	124,5	160,3	180,2	191,9	198,3	201,2	201,3	199,3	231,8	298,5	335,5	357,2	369,3	374,6	374,8	371,1
R404a	-40	119,8	148,6	162,8	169,8	172,3	171,9	169,2	164,7	223,0	276,6	303,1	316,1	320,9	320,0	315,0	306,7
	-30	118,0	148,2	163,7	171,7	175,2	175,6	173,6	169,8	219,7	276,0	304,7	319,7	326,2	326,9	323,2	316,1
	-20	115,0	146,1	162,6	171,6	176,0	177,1	175,7	172,5	214,0	272,1	302,8	319,6	327,6	329,7	327,2	321,3
	-10	110,8	142,3	159,5	169,3	174,4	176,1	175,4	172,7	206,3	265,0	297,1	315,2	324,6	327,9	326,6	321,5
	-5	108,3	139,8	157,2	167,3	172,6	174,6	174,1	171,7	201,7	260,3	292,7	311,4	321,4	325,1	324,2	319,7
	10	99,4	129,7	147,1	157,5	163,3	165,8	165,8	163,7	185,0	241,6	273,9	293,2	304,0	308,7	308,6	304,8

Correction for subcooling Δt<sub>sub</sub>

The evaporator capacities used must be corrected if subcooling deviates from 4 K (7.2°F). The corrected capacity can be obtained by

dividing the required evaporator capacity by the correction factor below. Selections can then be made from the tables above.

Correction factor	Δt <sub>sub</sub>									
	4 K	10 K	15 K	20 K	25 K	30 K	35 K	40 K	45 K	50 K
	7.2°F	18°F	27°F	36°F	45°F	54°F	63°F	72°F	81°F	90°F
R22	1,00	1,06	1,11	1,15	1,20	1,25	1,30	1,35	1,39	1,44
R410A	1,00	1,08	1,15	1,21	1,27	1,33	1,39	1,45	1,50	1,56
R407C	1,00	1,08	1,14	1,21	1,27	1,33	1,39	1,45	1,51	1,57
R134a	1,00	1,08	1,13	1,19	1,25	1,31	1,37	1,42	1,48	1,54
R404A / R507	1,00	1,10	1,20	1,29	1,37	1,46	1,54	1,63	1,70	1,78

Note: Insufficient subcooling can produce flash gas.



Capacities

Range -40°C to +10°C

SI units

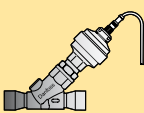
	t <sub>e</sub> [°C]	Rated capacity [kW]															
		ETS 250								ETS 400							
		Pressure drop Δp [bar]															
		2	4	6	8	10	12	14	16	2	4	6	8	10	12	14	16
R407C	-40	811	1017	1129	1195	1232	1249	1252	1244	1294	1622	1801	1905	1964	1992	1997	1984
	-30	806	1022	1141	1213	1255	1277	1284	1280	1286	1629	1820	1934	2002	2037	2049	2041
	-20	794	1017	1143	1220	1268	1295	1306	1305	1266	1621	1823	1947	2023	2065	2083	2082
	-10	774	1002	1133	1216	1269	1300	1315	1317	1235	1598	1808	1940	2024	2073	2097	2101
	-5	762	990	1124	1209	1264	1297	1314	1318	1215	1580	1793	1929	2016	2068	2095	2102
	10	715	941	1078	1167	1226	1264	1285	1293	1141	1502	1719	1862	1956	2016	2049	2062
R22	-40	779	995	1122	1205	1261	1297	1320	1331	1243	1587	1790	1922	2011	2069	2105	2123
	-30	771	994	1126	1214	1273	1314	1339	1353	1230	1585	1796	1936	2031	2095	2136	2159
	-20	757	984	1121	1213	1277	1320	1349	1366	1207	1569	1789	1935	2036	2106	2151	2178
	-10	737	966	1107	1202	1269	1315	1347	1366	1175	1541	1766	1918	2024	2098	2148	2179
	-5	724	954	1096	1193	1261	1309	1341	1361	1156	1522	1748	1903	2011	2087	2139	2171
	10	681	906	1049	1147	1218	1268	1303	1325	1086	1446	1673	1830	1942	2022	2078	2114
R134a	-40	684	832	902	934	943	937	919	891	1092	1328	1439	1490	1505	1494	1465	1422
	-30	688	847	924	963	977	975	960	937	1098	1351	1474	1535	1558	1555	1532	1494
	-20	686	854	939	983	1003	1005	995	975	1094	1362	1498	1569	1600	1603	1587	1555
	-10	677	853	945	995	1020	1027	1020	1003	1080	1360	1507	1587	1627	1637	1627	1600
	-5	670	849	944	997	1024	1033	1029	1014	1069	1354	1506	1591	1634	1648	1641	1617
	10	640	824	927	987	1020	1035	1035	1025	1021	1315	1478	1574	1627	1650	1651	1635
R404a	-40	615	763	836	871	884	881	867	844	981	1217	1333	1390	1410	1406	1383	1346
	-30	606	761	840	881	899	900	890	870	967	1214	1340	1406	1434	1436	1419	1387
	-20	591	750	835	881	903	908	901	884	942	1197	1332	1405	1440	1448	1437	1410
	-10	569	731	819	869	894	903	899	884	908	1166	1306	1386	1426	1440	1433	1411
	-5	556	718	807	858	885	895	892	879	887	1145	1287	1369	1412	1428	1423	1402
	10	510	666	755	807	837	849	849	838	814	1062	1204	1288	1335	1355	1354	1336

Correction for subcooling Δt<sub>sub</sub>

The evaporator capacities used must be corrected if subcooling deviates from 4 K (7.2°F). The corrected capacity can be obtained by

dividing the required evaporator capacity by the correction factor below. Selections can then be made from the tables above.

Correction factor	Δt <sub>sub</sub>									
	4 K	10 K	15 K	20 K	25 K	30 K	35 K	40 K	45 K	50 K
	7.2°F	18°F	27°F	36°F	45°F	54°F	63°F	72°F	81°F	90°F
R22	1,00	1,06	1,11	1,15	1,20	1,25	1,30	1,35	1,39	1,44
R410A	1,00	1,08	1,15	1,21	1,27	1,33	1,39	1,45	1,50	1,56
R407C	1,00	1,08	1,14	1,21	1,27	1,33	1,39	1,45	1,51	1,57
R134a	1,00	1,08	1,13	1,19	1,25	1,31	1,37	1,42	1,48	1,54
R404A / R507	1,00	1,10	1,20	1,29	1,37	1,46	1,54	1,63	1,70	1,78

**Note:** Insufficient subcooling can produce flash gas.

Capacities

Range -40°F to +50°F

US units

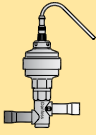
	t <sub>e</sub> [°F]	Rated capacity [TR]															
		ETS 12½								ETS 25							
		Pressure drop Δp [psig]															
		40	60	80	100	125	150	175	200	40	60	80	100	125	150	175	200
R410A	-40	14.9	17.2	18.9	20.1	21.3	22.1	22.7	23.2	30.7	35.5	38.8	41.4	43.7	45.5	46.7	47.6
	-20	14.6	16.9	18.6	19.9	21.1	22.0	22.7	23.1	29.9	34.8	38.3	40.9	43.4	45.2	46.6	47.6
	0	14.0	16.4	18.1	19.4	20.7	21.6	22.3	22.8	28.8	33.7	37.2	39.9	42.5	44.4	45.9	46.9
	20	13.3	15.7	17.4	18.7	20.0	20.9	21.6	22.2	27.4	32.2	35.7	38.4	41.0	43.0	44.5	45.5
	40	12.5	14.7	16.4	17.7	18.9	19.9	20.6	21.1	25.7	30.3	33.7	36.4	38.9	40.9	42.3	43.4
	50	12.0	14.2	15.8	17.1	18.3	19.2	19.9	20.5	24.7	29.2	32.5	35.1	37.6	39.6	41.0	42.1
R407C	-40	13.4	15.2	16.3	17.2	17.8	18.2	18.4	18.5	27.5	31.2	33.6	35.3	36.7	37.5	37.9	38.0
	-20	13.4	15.2	16.5	17.4	18.2	18.6	18.9	19.0	27.5	31.3	33.9	35.8	37.3	38.3	38.8	39.1
	0	13.2	15.1	16.5	17.4	18.3	18.8	19.2	19.3	27.1	31.1	33.9	35.9	37.6	38.7	39.4	39.7
	20	12.8	14.8	16.3	17.3	18.2	18.8	19.2	19.4	26.4	30.5	33.4	35.5	37.4	38.6	39.4	39.9
	40	12.4	14.4	15.8	16.9	17.8	18.5	18.9	19.2	25.4	29.5	32.5	34.7	36.6	38.0	38.9	39.4
	50	12.1	14.1	15.5	16.6	17.5	18.2	18.7	18.9	24.8	28.9	31.9	34.1	36.1	37.4	38.4	38.9
R22	-40	12.9	14.8	16.1	17.1	18.0	18.6	19.0	19.3	26.5	30.3	33.1	35.1	36.9	38.2	39.1	39.7
	-20	12.8	14.7	16.1	17.2	18.1	18.8	19.3	19.6	26.3	30.3	33.1	35.3	37.2	38.7	39.7	40.4
	0	12.6	14.6	16.0	17.1	18.1	18.8	19.4	19.8	25.8	29.9	32.9	35.1	37.2	38.7	39.8	40.6
	20	12.2	14.2	15.7	16.8	17.9	18.7	19.3	19.7	25.1	29.3	32.3	34.6	36.8	38.4	39.6	40.4
	40	11.7	13.8	15.3	16.4	17.5	18.3	18.9	19.3	24.1	28.3	31.4	33.7	35.9	37.6	38.9	39.7
	50	11.5	13.5	15.0	16.1	17.2	18.0	18.6	19.1	23.6	27.7	30.8	33.1	35.4	37.4	38.3	39.2
R134a	-40	11.2	12.4	13.1	13.6	13.9	13.9	13.8	13.6	22.9	25.5	27.0	27.9	28.5	28.6	28.4	27.9
	-20	11.3	12.6	13.5	14.0	14.3	14.5	14.5	14.3	23.2	26.0	27.7	28.8	29.5	29.8	29.7	29.3
	0	11.3	12.7	13.7	14.3	14.7	14.9	14.9	14.8	23.2	26.2	28.1	29.3	30.2	30.6	30.7	30.4
	20	11.2	12.7	13.7	14.4	14.9	15.1	15.2	15.2	22.9	26.1	28.1	29.5	30.6	31.1	31.3	31.2
	40	10.9	12.5	13.5	14.3	14.8	15.2	15.3	15.3	22.4	25.6	27.8	29.3	30.5	31.2	31.5	31.5
	50	10.7	12.3	13.4	14.1	14.8	15.3	15.1	15.3	22.0	25.3	27.5	29.1	30.3	31.1	31.4	31.4
R404a	-40	10.1	11.4	12.1	12.6	12.9	13.1	13.0	12.8	20.8	23.4	25.0	25.9	26.6	26.8	26.7	26.4
	-20	10.0	11.3	12.2	12.7	13.1	13.3	13.3	13.2	20.6	23.3	25.0	26.2	27.0	27.3	27.4	27.1
	0	9.8	11.1	12.0	12.6	13.1	13.4	13.4	13.3	20.0	22.9	24.8	26.0	27.0	27.4	27.5	27.4
	20	9.4	10.8	11.7	12.4	12.9	13.2	13.3	13.2	19.3	22.2	24.1	25.4	26.5	27.0	27.3	27.2
	40	8.9	10.3	11.2	11.9	12.4	12.7	12.9	12.8	18.2	21.1	23.0	24.4	25.5	26.1	26.4	26.4
	50	8.6	9.9	10.9	11.5	12.1	12.4	12.5	12.5	17.6	20.4	22.4	23.7	24.9	25.5	25.8	25.8

Correction for subcooling Δt<sub>sub</sub>

The evaporator capacities used must be corrected if subcooling deviates from 4 K (7.2°F). The corrected capacity can be obtained by

dividing the required evaporator capacity by the correction factor below. Selections can then be made from the tables above.

Correction factor	Δt <sub>sub</sub>									
	4 K	10 K	15 K	20 K	25 K	30 K	35 K	40 K	45 K	50 K
	7.2°F	18°F	27°F	36°F	45°F	54°F	63°F	72°F	81°F	90°F
R22	1.00	1.06	1.11	1.15	1.20	1.25	1.30	1.35	1.39	1.44
R410A	1.00	1.08	1.15	1.21	1.27	1.33	1.39	1.45	1.50	1.56
R407C	1.00	1.08	1.14	1.21	1.27	1.33	1.39	1.45	1.51	1.57
R134a	1.00	1.08	1.13	1.19	1.25	1.31	1.37	1.42	1.48	1.54
R404A / R507	1.00	1.10	1.20	1.29	1.37	1.46	1.54	1.63	1.70	1.78

Note: Insufficient subcooling can produce flash gas.

Capacities

Range -40°F to +50°F

US units

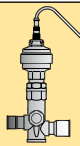
	t <sub>e</sub> [°F]	Rated capacity [TR]															
		ETS 50B								ETS 100B							
		Pressure drop Δp [psig]															
		40	60	80	100	125	150	175	200	40	60	80	100	125	150	175	200
R410A	-40	55,9	64,6	70,8	75,4	79,7	82,9	85,2	86,8	104,2	120,3	131,8	140,4	148,5	154,4	158,6	161,6
	-20	54,6	63,4	69,8	74,6	79,1	82,5	85,0	86,7	101,6	118,0	129,9	138,9	147,4	153,6	158,2	161,5
	0	52,6	61,4	67,9	72,8	77,5	81,0	83,6	85,5	97,8	114,3	126,4	135,6	144,3	150,9	155,7	159,2
	20	49,9	58,7	65,1	70,1	74,8	78,4	81,1	83,1	93,0	109,2	121,2	130,4	139,3	146,0	151,0	154,6
	40	46,8	55,2	61,4	66,3	71,0	74,6	77,2	79,2	87,1	102,7	114,4	123,5	132,2	138,8	143,8	147,5
	50	45,0	53,2	59,3	64,1	68,7	72,2	74,8	76,8	83,8	99,0	110,4	119,3	127,8	134,4	139,3	142,9
R407C	-40	50,4	57,3	61,9	65,1	67,9	69,6	70,6	71,0	93,9	106,6	115,2	121,2	126,4	129,6	131,5	132,2
	-20	50,4	57,6	62,5	66,0	69,1	71,1	72,4	73,0	93,8	107,2	116,4	122,9	128,7	132,4	134,7	135,9
	0	49,7	57,2	62,5	66,3	69,6	71,9	73,4	74,2	92,6	106,6	116,3	123,4	129,6	133,9	136,6	138,2
	20	48,5	56,2	61,7	65,7	69,3	71,8	73,5	74,6	90,4	104,7	114,9	122,3	129,1	133,8	136,9	138,8
	40	46,8	54,6	60,1	64,3	68,1	70,8	72,7	73,9	87,1	101,6	111,9	119,7	126,8	131,8	135,3	137,5
	50	45,7	53,5	59,0	63,2	67,1	69,9	71,8	73,1	85,2	99,5	109,9	117,7	125,0	130,1	133,7	136,1
R22	-40	48,5	55,6	60,6	64,3	67,7	70,1	71,8	72,9	90,3	103,6	112,9	119,8	126,1	130,5	133,7	135,7
	-20	48,1	55,5	60,8	64,7	68,3	70,9	72,8	74,0	89,6	103,4	113,1	120,4	127,2	132,0	135,5	137,8
	0	47,3	54,9	60,3	64,4	68,2	71,0	73,1	74,5	88,1	102,2	112,3	119,9	127,1	132,3	136,0	138,7
	20	46,0	53,6	59,2	63,5	67,5	70,4	72,6	74,1	85,6	99,9	110,3	118,1	125,6	131,1	135,1	138,0
	40	44,2	51,9	57,5	61,8	65,9	68,9	71,2	72,9	82,3	96,6	107,0	115,0	122,7	128,4	132,6	135,7
	50	43,2	50,8	56,4	60,7	64,8	67,9	70,2	71,9	80,4	94,5	104,9	112,9	120,6	126,4	130,7	133,8
R134a	-40	41,8	46,4	49,2	50,9	51,9	52,2	51,8	50,9	77,7	86,4	91,6	94,7	96,7	97,1	96,4	94,8
	-20	42,3	47,3	50,4	52,4	53,8	54,2	54,1	53,4	78,7	88,1	93,9	97,6	100,1	101,0	100,7	99,5
	0	42,3	47,7	51,1	53,4	55,1	55,8	55,9	55,5	78,7	88,8	95,2	99,4	102,5	103,9	104,1	103,3
	20	41,8	47,5	51,3	53,8	55,7	56,7	57,0	56,8	77,8	88,5	95,4	100,1	103,7	105,6	106,2	105,8
	40	40,8	46,7	50,7	53,4	55,6	56,9	57,4	57,4	75,9	87,0	94,4	99,5	103,6	105,9	106,9	106,8
	50	40,1	46,1	50,1	53,0	55,3	56,6	57,2	57,3	74,6	85,8	93,4	98,6	102,9	105,4	106,6	106,7
R404a	-40	37,9	42,6	45,6	47,4	48,6	49,0	48,9	48,2	70,6	79,4	84,8	88,2	90,5	91,3	91,0	89,8
	-20	37,5	42,5	45,7	47,8	49,3	50,0	50,0	49,6	69,9	79,2	85,1	89,0	91,8	93,0	93,1	92,3
	0	36,6	41,8	45,2	47,5	49,2	50,1	50,4	50,1	68,1	77,8	84,2	88,4	91,7	93,3	93,8	93,3
	20	35,2	40,5	44,0	46,4	48,4	49,4	49,8	49,7	65,5	75,3	81,9	86,4	90,1	92,0	92,8	92,6
	40	33,3	38,5	42,1	44,6	46,6	47,8	48,3	48,3	62,0	71,7	78,4	83,0	86,8	89,0	90,0	89,9
	50	32,2	37,3	40,9	43,4	45,4	46,6	47,2	47,2	59,9	69,5	76,1	80,7	84,6	86,8	87,8	87,8

Correction for subcooling Δt<sub>sub</sub>

The evaporator capacities used must be corrected if subcooling deviates from 4 K (7.2°F). The corrected capacity can be obtained by

dividing the required evaporator capacity by the correction factor below. Selections can then be made from the tables above.

Correction factor	Δt <sub>sub</sub>									
	4 K	10 K	15 K	20 K	25 K	30 K	35 K	40 K	45 K	50 K
	7.2°F	18°F	27°F	36°F	45°F	54°F	63°F	72°F	81°F	90°F
R22	1,00	1,06	1,11	1,15	1,20	1,25	1,30	1,35	1,39	1,44
R410A	1,00	1,08	1,15	1,21	1,27	1,33	1,39	1,45	1,50	1,56
R407C	1,00	1,08	1,14	1,21	1,27	1,33	1,39	1,45	1,51	1,57
R134a	1,00	1,08	1,13	1,19	1,25	1,31	1,37	1,42	1,48	1,54
R404A / R507	1,00	1,10	1,20	1,29	1,37	1,46	1,54	1,63	1,70	1,78

Note: Insufficient subcooling can produce flash gas.

Capacities

Range -40°F to +50°F

US units

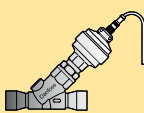
	t <sub>e</sub> [°F]	Rated capacity [TR]															
		ETS 250								ETS 400							
		Pressure drop Δp [psig]															
		40	60	80	100	125	150	175	200	40	60	80	100	125	150	175	200
R407C	-40	258	292	315	331	344	351	355	356	411	466	502	527	548	561	567	568
	-20	257	293	318	335	350	359	364	366	410	468	507	535	558	573	581	584
	0	254	292	317	336	352	363	369	372	405	465	506	536	562	579	589	594
	20	247	286	313	333	350	362	369	374	395	456	499	531	559	577	589	596
	40	238	277	305	325	343	356	364	369	380	442	486	518	548	568	581	589
	50	232	271	299	319	338	351	360	365	371	432	476	509	539	560	574	582
R22	-40	250	286	312	331	348	361	369	375	398	456	497	528	556	575	589	598
	-20	248	286	313	333	351	365	374	381	395	455	499	531	560	582	597	607
	0	243	282	310	331	351	365	376	383	388	450	495	528	560	583	599	611
	20	236	276	305	326	347	362	373	381	377	440	486	521	553	578	595	608
	40	227	267	296	318	339	355	366	375	363	425	471	507	540	566	584	598
	50	222	261	290	312	333	349	361	370	354	416	462	498	531	557	576	590
R134a	-40	215	239	253	262	267	268	266	262	342	381	404	417	426	428	425	418
	-20	217	243	259	269	276	279	278	275	347	388	414	430	441	445	444	439
	0	217	245	263	275	283	287	288	285	347	391	420	438	452	458	459	455
	20	215	244	264	276	286	292	293	292	343	390	420	441	457	465	468	466
	40	210	240	261	275	286	292	295	295	334	383	416	438	456	466	471	470
	50	206	237	258	272	284	291	294	295	329	378	411	434	453	464	469	470
R404a	-40	195	219	234	243	249	252	251	247	311	349	373	388	398	401	400	394
	-20	193	218	235	245	253	256	256	254	307	348	374	391	403	409	409	405
	0	188	215	232	244	253	257	258	257	300	342	370	389	403	410	412	410
	20	181	208	226	238	248	253	256	255	288	331	360	380	396	404	408	406
	40	171	198	216	229	239	245	248	247	273	315	344	365	381	391	395	395
	50	165	192	210	222	233	239	242	242	263	306	334	355	371	381	385	385

Correction for subcooling Δt<sub>sub</sub>

The evaporator capacities used must be corrected if subcooling deviates from 4 K (7.2°F). The corrected capacity can be obtained by

dividing the required evaporator capacity by the correction factor below. Selections can then be made from the tables above.

Correction factor	Δt <sub>sub</sub>									
	4 K	10 K	15 K	20 K	25 K	30 K	35 K	40 K	45 K	50 K
	7.2°F	18°F	27°F	36°F	45°F	54°F	63°F	72°F	81°F	90°F
R22	1,00	1,06	1,11	1,15	1,20	1,25	1,30	1,35	1,39	1,44
R410A	1,00	1,08	1,15	1,21	1,27	1,33	1,39	1,45	1,50	1,56
R407C	1,00	1,08	1,14	1,21	1,27	1,33	1,39	1,45	1,51	1,57
R134a	1,00	1,08	1,13	1,19	1,25	1,31	1,37	1,42	1,48	1,54
R404A / R507	1,00	1,10	1,20	1,29	1,37	1,46	1,54	1,63	1,70	1,78

**Note:** Insufficient subcooling can produce flash gas.

Dimension and weight for ETS 12½ and 25

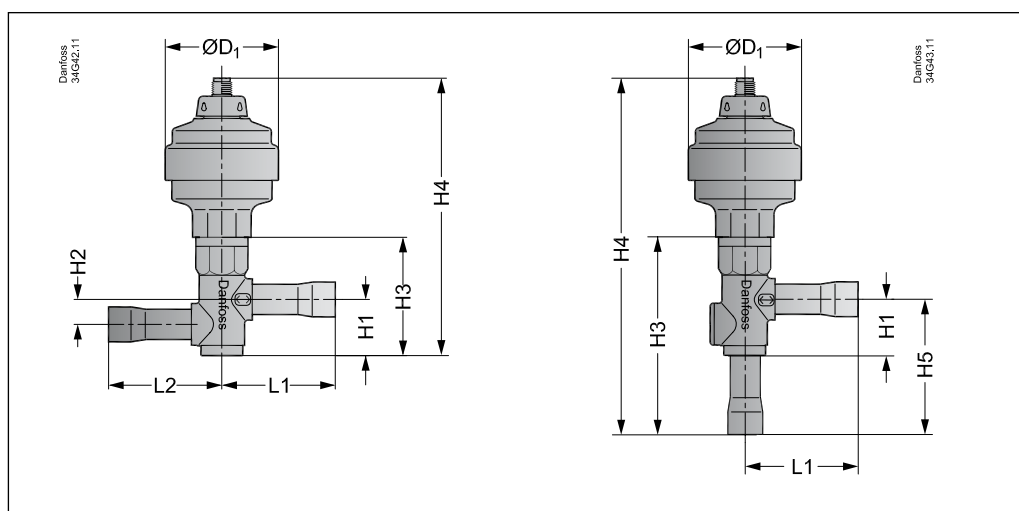

Type	Connections, ODF solder		H <sub>1</sub>		H <sub>2</sub>		H <sub>3</sub>		H <sub>4</sub>		H <sub>5</sub>		L <sub>1</sub>		L <sub>2</sub>		ØD <sub>1</sub>		Weight	
	In × out	In × out	mm	in.	mm	in.	mm	in.	mm	in.	mm	in.	mm	in.	mm	in.	mm	in.	kg	lb.
ETS 12½ straight	½ × ½	12 × 12	30	1.2	13	0.5	64	2.5	145	5.7			60	2.4	60	2.4	58	2.3	0.7	1.5
	⅝ × ⅝	16 × 16																		
	⅞ × ⅞	22 × 22																		
ETS 25 angle	½ × ½	12 × 12	30	1.2			64	2.5	145	5.7	74	2.9	60	2.4			58	2.3	0.7	1.5
	⅝ × ⅝	16 × 16																		
	⅞ × ⅞	22 × 22																		

Dimension and weight for ETS 50 and 100

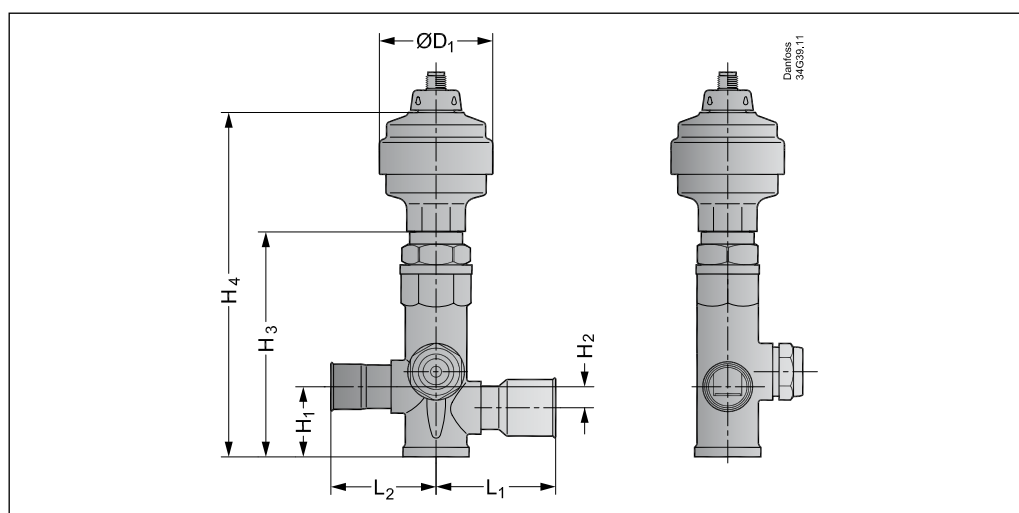

Type	Connections, ODF solder		H <sub>1</sub>		H <sub>2</sub>		H <sub>3</sub>		H <sub>4</sub>		L <sub>1</sub>		L <sub>2</sub>		ØD <sub>1</sub>		Weight	
	Input × output	Input × output	mm	in.	mm	in.	mm	in.	mm	in.	mm	in.	mm	in.	mm	in.	kg	lb.
ETS 50	⅞ × ⅞	22 × 22	26,2	1,0	13,0	0,5	120,0	4,7	220,0	8,7	56,0	2,2	56,0	2,2	60,0	2,4	1,5	3,3
	⅞ × 1⅛	22 × 28											63,0	2,5				
	⅞ × 1⅜	22 × 35											74,0	2,9				
	1⅛ × 1⅛	28 × 28											63,0	2,5				
	1⅛ × 1⅜	28 × 35											74,0	2,9				
ETS 100	1⅛ × 1⅛	28 × 28	30,0	1,2	17,0	0,7	127,0	5,0	221,0	8,7	66,0	2,6	66,0	2,6	60,0	2,4	1,7	3,7
	1⅛ × 1⅜	28 × 35											76,0	3,0				
	1⅛ × 1⅝	28 × 42											84,0	3,3				
	1⅜ × 1⅜	35 × 35											76,0	3,0				
	1⅜ × 1⅝	35 × 42											84,0	3,3				

For further information please contact Danfoss

Dimension and weight for ETS 250 and 400

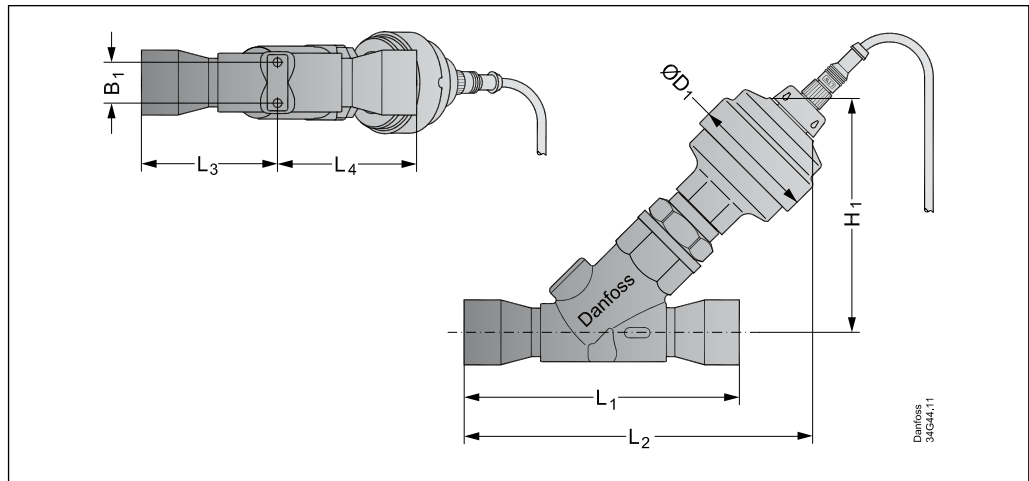

Type	Connections, ODF solder		H <sub>1</sub>		L <sub>1</sub>		L <sub>2</sub>		L <sub>3</sub>		L <sub>4</sub>		øD <sub>1</sub>		B <sub>1</sub>		Weight	
	Input × output	Input × output	mm	in	mm	in	mm	in	mm	in	mm	in	mm	in	mm	in	kg	lb
ETS 250	1 <sup>1</sup> / <sub>8</sub> × 1 <sup>1</sup> / <sub>8</sub>	28 × 28	133,5	5,3	168,5	6,7	203,0	8,0	83,0	3,3	85,5	3,4	60,0	2,4	24,0	0,95	1,9	4,2
	1 <sup>3</sup> / <sub>8</sub> × 1 <sup>3</sup> / <sub>8</sub>	35 × 35			178,5	7,0	208,0	8,2	88,0	3,5	90,5	3,6						
	1 <sup>5</sup> / <sub>8</sub> × 1 <sup>5</sup> / <sub>8</sub>	42 × 42			188,5	7,4	213,0	8,4	93,0	3,7	95,5	3,8						
ETS 400	1 <sup>5</sup> / <sub>8</sub> × 1 <sup>5</sup> / <sub>8</sub>	42 × 42	133,5	5,3	203,0	8,0	214,0	8,4	99,0	3,9	104,0	4,1	60,0	2,4	24,0	0,95	2,2	4,9
	2 <sup>1</sup> / <sub>8</sub> × 2 <sup>1</sup> / <sub>8</sub>	54 × 54			243,0	9,6	234,0	9,2	119,0	4,7	124,0	4,9						

For further information please contact Danfoss